

## Front and profile views

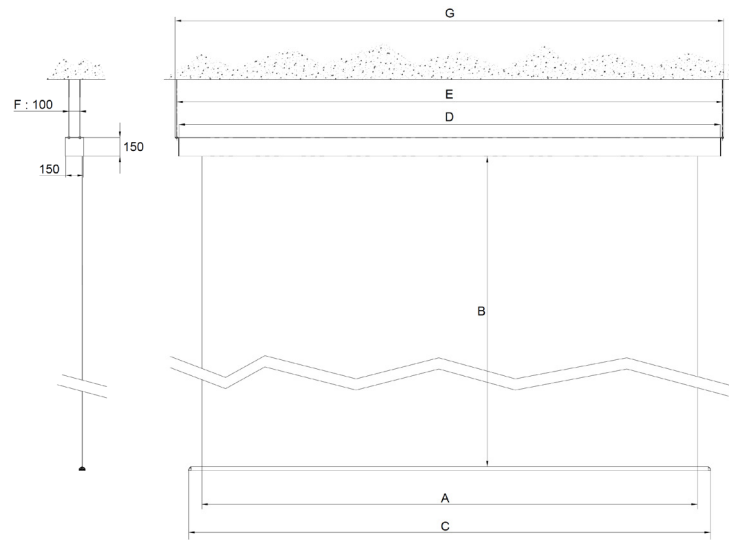

- A Image base
- B Image height
- C Weighing bar length
- D Casing length
- E Fixing center distance
- F Fixing center distance
- G Overall casing length

Other DIMENSIONS,  
FABRICS,  
COLORS  
on request

## Technical data

Jumbo PRO Reference	A cm	B cm	C cm	D cm	E cm	F cm	G cm
<b>4:3 Format</b>							
					Fixing center distance		
JU1B1180240	240	180	254,9	255,5	259,3	10	262,3
JU1B1202270	270	202	284,9	285,5	289,3	10	292,3
JU1B1225300	300	225	314,9	315,5	319,3	10	322,3
JU1B1263350	350	263	364,9	365,5	369,3	10	372,3
JU1B1300400	400	300	414,9	415,5	419,3	10	422,3
JU1B1375500	500	375	514,9	515,5	519,3	10	522,3
<b>16:10 Format</b>							
JU1B1150240	240	150	254,9	255,5	259,3	10	262,3
JU1B1169270	270	169	284,9	285,5	289,3	10	292,3
JU1B1187300	300	187	314,9	315,5	319,3	10	322,3
JU1B1219350	350	219	364,9	365,5	369,3	10	372,3
JU1B1250400	400	250	414,9	415,5	419,3	10	422,3
JU1B1312500	500	312	514,9	515,5	519,3	10	522,3
<b>1:1 Format</b>							
JU1B1240240	240	240	254,9	255,5	259,3	10	262,3
JU1B1270270	270	270	284,9	285,5	289,3	10	292,3
JU1B1300300	300	300	314,9	315,5	319,3	10	322,3
JU1B1400400	400	400	414,9	415,5	419,3	10	422,3

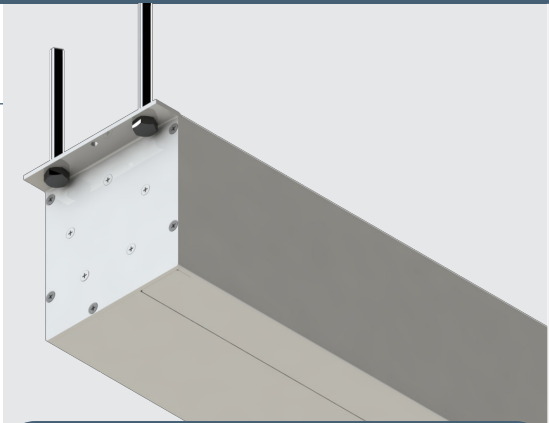

In addition to its reliability, this top of the range screen offers you a full screen image format.



- M1 Fire resistant projection surface
- The weighing bar closes the whole case in stand-up position
- Remote control in option
- Wired switch included
- Motor on the right

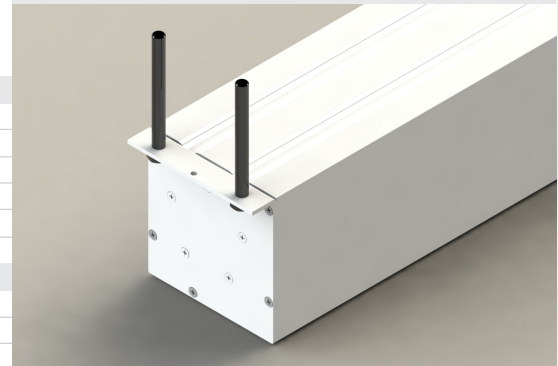

Chemin de Beaurepaire  
91410 DOURDAN - FRANCE  
Tel +33 1 64 59 94 54



www.oray.fr

### Stand-off brackets

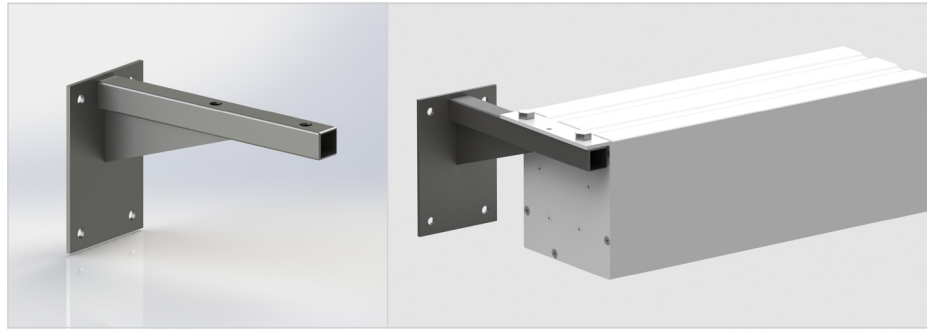

### STAND-OFF BRACKETS

The pair	Reference
10cm	OPTECAR10JU
20cm	OPTECAR20JU
30cm	OPTECAR30JU
40cm	OPTECAR40JU

### Wall mounting

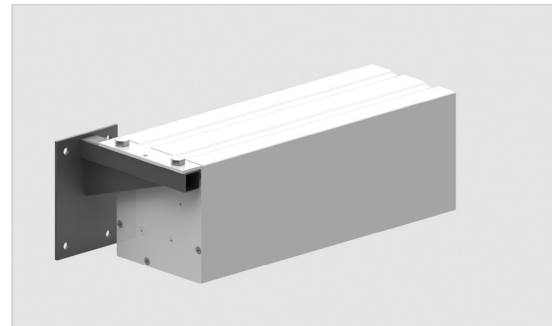

### WALL MOUNTING

Unit	Reference
The pair	PATMURJUM15



Before fixing to the wall with or without stand-off brackets: make sure that the wall will support the weight of the screen.

### Barrel mounting

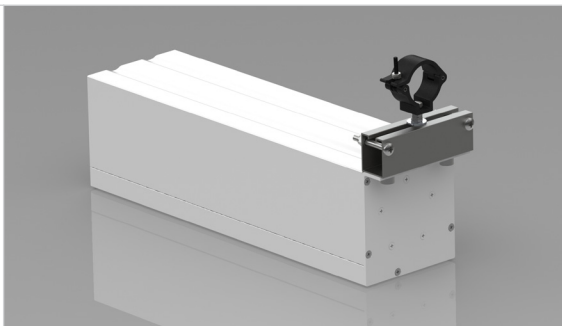

### Suspended mounting

Set 1m threaded rods and fixing brackets

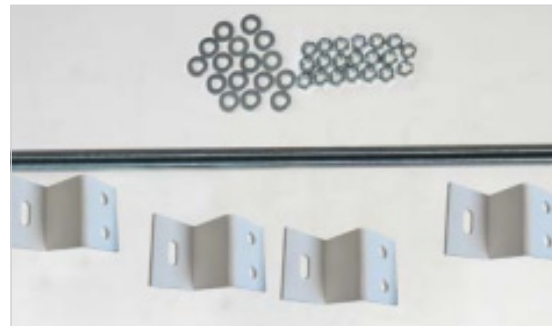

### BARREL MOUNTING

Unit	Reference
The pair	PATPERJUM01

### SUSPENDED MOUNTING

Unit	Reference
1 kit	OPTKITOP2

Chemin de Beaurepaire  
91410 DOURDAN - FRANCE  
Tel +33 1 64 59 94 54