

**ORAY**

**HOME CINEMA AND RESIDENTIAL**

———— 2024 Edition ————



### HOME CINEMA AND RESIDENTIAL

projection screens  
videoprojectors mounts  
flat screens mounts



### PROFESSIONAL AND OFFICES

projection screens  
videoprojectors mounts  
flat screens mounts



### STAGES AND EVENTS

projection screens  
cycloramas

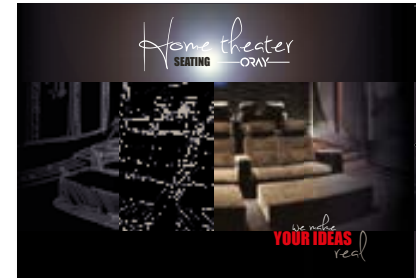

### HOME CINEMA SEATS

individual seats  
custom-made rows  
D-BOX Technology



# Our range of screens HOME CINEMA and RESIDENTIAL

## ORAY COMPANY p 4

## ROLL-UP p 5

Squar'	p 6
HCM4	p 8
Orion	p 9
Jumbo	p 10
Inceling Orion	p 12
Pantoscreen without casing	p 13
Pantoscreen with casing	p 14
Remote controls	p 15

## MANALS p 16

Super Gear	p 17
Oray 2000	p 18

## NOMADS p 19

Butterfly mobile	p 20
Fly	p 21
Dragonfly, Cross Screen, Miniscreen	p 22
Style, Byron 2, Screen	p 23

## FRAMES p 24

Special video	p 25
Cadre HC	p 26
Cineframe	p 27
Cineframe UST-ALR	p 28
Le Mask	p 29
Cinevision I	p 30

## CUSTOM-MADE FABRICS p 31

Projection surfaces	p 32
Finishes	p 33

## MOUNTS p 34

<b>For video projectors</b>	
Motorised mounts	p 35
Fixed mounts	p 36
<b>For flat screens</b>	
Fixed mounts	p 37



This catalogue is printed on paper from responsible sources and from sustainably managed forests.



**FIRE RESISTANT CLASSIFICATION**  
Classification of the projection surface.



**ANY HEIGHT STOP**  
The screen can stop at several heights.



**SPEED SOLO SYSTEM**  
Easier and faster mounting by only one person.



**CUSTOMIZABLE**  
You can choose another projection surface or ask for a product adapted to your measurements.



**ADJUSTABLE HEIGHT**  
Adjusting the height of projection.



**PRINTING ON FABRIC**  
Possibility to personalise the fabric.



**ULTRA SHORT THROW**  
Model compatible with an Ultra Short Throw video projector



**MAXIMUM LOAD**



**CASING COLOR RAL**  
Other color maps on request, according to the references of RAL colour.



## QUALITY Know-how since 1947

The company ORAY, based south west of Paris, is dedicated to:

- The DESIGNING
- The MANUFACTURING
- The MARKETING

of projector screens and audiovisual accessories.

## TECHNOLOGY WATCH N°1 in France

The most exhaustive range  
Through continuous search of new products and the wish to adapt as closely as possible to the technical developments of projection, the company is the number 1 in France in the industry of projection screens and is one of the leaders worldwide.

## SUSTAINABLE DEVELOPMENT Eco-socio-conception

Social and environmental issues are a priority for ORAY. These commitments led the company to engage several actions in order to improve its global performance in a forward-looking business model:

- ECONOMICAL performance
- SOCIAL performance
- ENVIRONMENTAL performance

Keen to offer the best value for money on the whole range, ORAY takes special care of the choice of materials, the quality of the assembly and the innovative product designs.



A range of standard and customized products to suit all projects: quiet motors, high standard of finishes, choice of projection surfaces, casings, customised fabrics, etc ...

## ROLL-UP

- Squar' p 6
- HCM4 p 8
- Orion p 9
- Jumbo p 10
- Inceiling Orion p 12
- Pantoscreen without casing p 13
- Pantoscreen with casing p 14
- Remote controls p 15



# SQUAR'HC

The **SQUAR'** is a very functional screen, ultra compact and simple to recess with its white lacquered aluminium case.



- The triangular weighing bar is perfectly integrated in the casing when the screen is rolled up.
- Wall or ceiling mounting included.

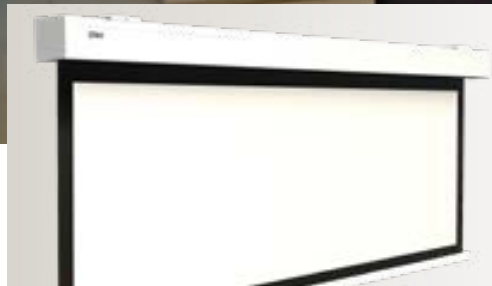

Triangular weighing bar

Wire switch included

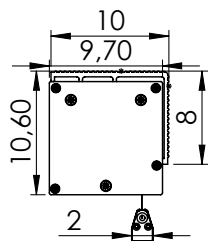

Casing profile  
Power supply on the right

## SQUAR' HC



Image format Ht x Base (cm)	Matt white Reference	Casing Length (cm)
<b>16:10 format 4 cm black borders+ 20 cm drop</b>		
120 x 192	SQ2B4120192	212,1
145 x 232	SQ2B4145232	252,1
164 x 262	SQ2B4164262	282,1
183 x 292	SQ2B4183292	312,1
214 x 342 no drop	SQ2B4214342	362,1
<b>4:3 format 4 cm black borders</b>		
144 x 192	SQ2B4144192	212,1
174 x 232	SQ2B4174232	252,1
196 x 262	SQ2B4196262	282,1
219 x 292	SQ2B4219292	312,1
<b>16:9 format 4 cm black borders+ 30 cm drop</b>		
108 x 192	SQ2B4108192	212,1
130 x 232	SQ2B4130232	252,1
147 x 262	SQ2B4147262	282,1
164 x 292	SQ2B4164292	312,1
192 x 342 no drop	SQ2B4192342	362,1



Remote controls  
optional p15



- FALSE-CEILING INTEGRATION
- ULTRA COMPACT

# Accessories for SQUAR'

The **UNDERFACE +** for SQUAR' screens is easy to install and aesthetic:

It offers a 2 in 1 solution for the integration of your screen in a false ceiling.



Closed system



Underface +



False-ceiling mounting set for underface +  
1m threaded rods and fixing brackets

The **STAND-OFF BRACKETS** can space the screen from the wall. Must be used without an underface.



Stand-off brackets, for wall offset.  
One pair up to 300 cm base.  
A trio for model 350 cm base.

## 2 POSSIBILITIES FOR INSTALLATION:

### 1 One shot installation:

- Installation of the screen at the same time of the underface.

### 2 Installation in two phases:

- installation of the underface + during false ceiling construction.
- installation of the screen in the underface+ when works are finished.

### UNDERFACE +



Screen base (cm)	Reference
172	SQ4180
192	SQ4200
232	SQ4240
262	SQ4270
292	SQ4300
342	SQ4350

### FALSE-CEILING KIT

1 kit for one underface	Reference
Up to 3m base	OPTKITFIX01
for SQ4350	OPTKITFIX02

### STAND-OFF BRACKETS



The pair	Reference
10 cm	OPTECAR10BSQ
20 cm	OPTECAR20BSQ
The trio	Reference
10 cm	OPTECAR10BSQ3
20 cm	OPTECAR20BSQ3



- VERY SIMPLE INTEGRATION

# HCM4

The **HCM4** design screen offers a quick and easy installation thanks to the Speed solo system.

## PLUG AND PLAY:

Ready to plug into your wall socket!



- Aluminum profile casing with white epoxy finish and black borders on the projection surface.
- Black out projection surface.
- Wall or ceiling mounting.

Two models available:

- HCM4S with wired control (see options for this model - page 23)
- HCM4R with infrared remote control and wired switch integrated on the receiver

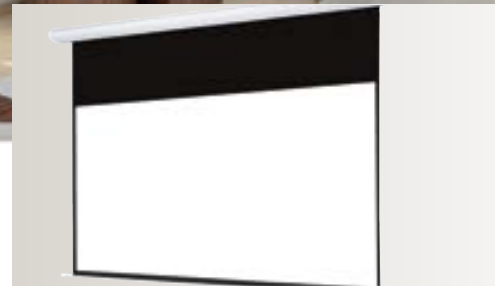

Stand-off bracket for a 10 or 20 cm wall distance

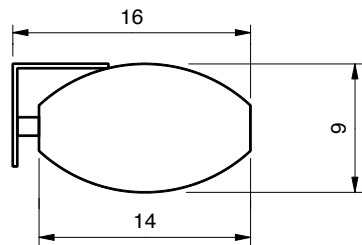

Casing profile  
Power supply on the right

## HCM4R and HCM4S



Image format Ht x Base (cm)	Ref. HCM4R Matt white + infrared remote control	Ref. HCM4S Matt white + Wired remote control	Casing length (cm)
<b>4:3 format</b>	<b>4 cm black borders</b>		
144 x 192	HCM4RB1150200	HCM4SB1150200	220
174 x 232	HCM4RB1180240	HCM4SB1180240	260
<b>16:9 format</b>	<b>4 cm black borders+ 30cm drop</b>		
97 x 172	HCM4RB1101180	HCM4SB1101180	200
108 x 192	HCM4RB1112200	HCM4SB1112200	220
130 x 232	HCM4RB1135240	HCM4SB1135240	260
<b>16:10 format</b>	<b>4 cm black borders+ 20cm drop</b>		
120 x 192	HCM4RB1125200	HCM4SB1125200	220
145 x 232	HCM4RB1150240	HCM4SB1150240	260



infrared remote control



Wired remote control

## STAND-OFF BRACKETS



The pair	Reference
10 cm	OPTECAR10
20 cm	OPTECAR20



Remote controls optional p15

- SILENT
- DESIGN
- NO VISIBLE SCREW



# ORION HC OR TENSIONED

The top of the range motorised screen, **ORION**, ensures its user reliability, aesthetics and uncompromising integration.

This product has been designed for easy installation, whatever the constraints, thanks to the Speed Solo system.

It has a protective housing with no visible screw other colours on request.

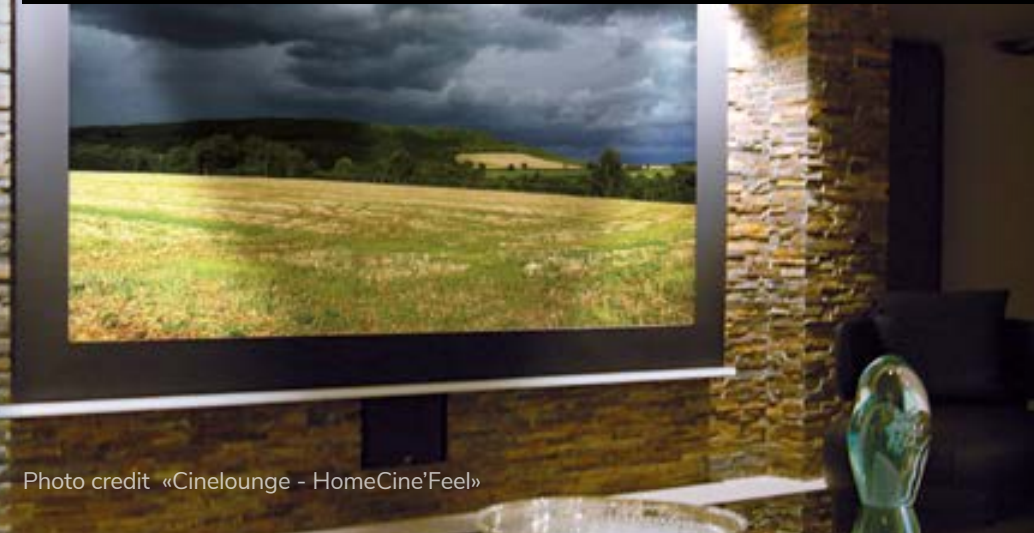
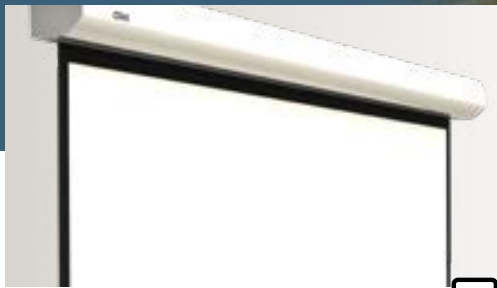

Photo credit «Cinelounge - HomeCine'Feel»

- The **tensioned version** is the only possible compromise for ultrashort-throw projection if a fixed frame screen is not possible. The lateral cables allow the tensioned projection surface to remain flat regardless of the screen's environment.
- Standard stand-off-brackets allow wall or ceiling mounting.
- Possibility of customising by printing all or part of the surface of the screen (logo, visual, texts...)



Motor cut-off security device when closing

## ORION HC Black out Matt white

Image (cm)	Reference	Section	Casing length
<b>6:10 format</b>	<b>4cm black borders+ 20cm drop</b>		
120 x 192	OR2B5120192	Small casing	216
145 x 232	OR2B5145232	Small casing	256
164 x 262	OR2B5164262	Small casing	286
182 x 292	OR2B5182292	Large casing	316
214 x 342	OR2B5214342	Large casing	366
245 x 392	OR2B5245392	Large casing	417
307 x 492	OR2B5307492	Large casing	517

Image (cm)	Reference	Section	Casing length
<b>4:3 format</b>	<b>4cm black borders</b>		
129 x 172	OR2B5129172	Small casing	196
144 x 192	OR2B5144192	Small casing	216
174 x 232	OR2B5174232	Small casing	256
196 x 262	OR2B5196262	Small casing	286
219 x 292	OR2B5219292	Large casing	316
257 x 342	OR2B5257342	Large casing	366
294 x 392	OR2B5294392	Large casing	417
369 x 492	OR2B5369492	Large casing	517

Image (cm)	Reference	Section	Casing length
<b>16:9 format</b>	<b>4cm black borders+ 30cm drop</b>		
108 x 192	OR2B5108192	Small casing	216
130 x 232	OR2B5130232	Small casing	256
147 x 262	OR2B5147262	Small casing	286
164 x 292	OR2B5164292	Large casing	316
192 x 342	OR2B5192342	Large casing	366
220 x 392	OR2B5220392	Large casing	417
277 x 492	OR2B5277492	Large casing	517

## ORION TENSIONED Black out Matt white

Image (cm)	Reference	Section	Casing length
<b>16:10 format</b>	<b>4cm black borders+ 20cm drop</b>		
120 x 192	OR3B5120192	Small casing	244
145 x 232	OR3B5145232	Small casing	284
164 x 262	OR3B5164262	Large casing	314
182 x 292	OR3B5182292	Large casing	344
214 x 342	OR3B5214342	Large casing	394
245 x 392	OR3B5245392	Large casing	444
307 x 492	OR3B5307492	Large casing	544

Image (cm)	Reference	Section	Casing length
<b>4:3 format</b>	<b>4cm black borders</b>		
129 x 172	OR3B5129172	Small casing	224
144 x 192	OR3B5144192	Small casing	244
174 x 232	OR3B5174232	Small casing	284
196 x 262	OR3B5196262	Small casing	314
219 x 292	OR3B5219292	Large casing	344
257 x 342	OR3B5257342	Large casing	394
294 x 392	OR3B5294392	Large casing	444

Image (cm)	Reference	Section	Casing length
<b>16:9 format</b>	<b>4cm black borders+ 30cm drop</b>		
108 x 192	OR3B5108192	Small casing	244
130 x 232	OR3B5130232	Small casing	284
147 x 262	OR3B5147262	Small casing	314
164 x 292	OR3B5164292	Large casing	344
192 x 342	OR3B5192342	Large casing	394
220 x 392	OR3B5220392	Large casing	444
277 x 492	OR3B5277492	Large casing	544

## STAND-OFF BRACKETS by pair or trio depending on the length of the casing

Screen base < 3 m	The pair
Reference	Offset
OPTECAR10GOR2	10 cm
OPTECAR20GOR2	20 cm
OPTECAR30GOR2	30 cm
OPTECAR40GOR2	40 cm

3m ≥ screen < 5m	The trio
Reference	Offset
OPTECAR10GOR3	10 cm
OPTECAR20GOR3	20 cm
OPTECAR30GOR3	30 cm
OPTECAR40GOR3	40 cm

Screen = 5 m	The trio
Reference	Offset
OPTECAR10GOR5	10 cm
OPTECAR20GOR5	20 cm
OPTECAR30GOR5	30 cm
OPTECAR40GOR5	40 cm

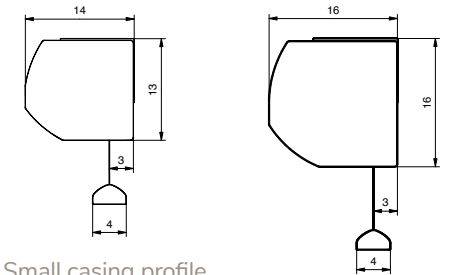

Small casing profile Power supply on the right Large casing profile



- **MOTOR CUT-OFF SECURITY**
- **CASE WITHOUT VISIBLE SCREW**

# ORION JUMBO HC or TENSIONED

The **ORION JUMBO** is a high-end motorised screen that offers not only reliability and aesthetics, but also a full-screen image format.

Its square-section housing allows easy integration.



- The **tensioned version** is the only possible compromise for ultrashort-throw projection if a fixed frame screen is not possible. The lateral cables allow the tensioned projection surface to remain flat regardless of the screen's environment.
- Possibility of customising by printing all or part of the surface of the screen (logo, visual, texts...)



## JUMBO HC Black out Matt White



Image (cm)	Reference	Lg length (cm)
<b>16:10 4cm black borders+ 20cm drop</b>		
145 x 232	JU2B5145232	256
164 x 262	JU2B5164262	286
182 x 292	JU2B5182292	316
214 x 342	JU2B5214342	366
245 x 392	JU2B5245392	417
307 x 492	JU2B5307492	517
<b>4:3 4cm black borders</b>		
174 x 232	JU2B5174232	256
196 x 262	JU2B5196262	286
219 x 292	JU2B5219292	316
257 x 342	JU2B5257342	366
294 x 392	JU2B5294392	417
369 x 492	JU2B5369492	517
<b>16:9 4 cm black borders + 30cm drop</b>		
130 x 232	JU2B5130232	256
147 x 262	JU2B5147262	286
164 x 292	JU2B5164292	316
192 x 342	JU2B5192342	366
220 x 392	JU2B5220392	417
277 x 492	JU2B5277492	517

## JUMBO TENSIONED Black out Matt White



Image (cm)	Reference	Lg length (cm)
<b>16:10 4cm black borders+ 20cm drop</b>		
145 x 232	JU3B5145232	280
164 x 262	JU3B5164262	310
182 x 292	JU3B5182292	340
214 x 342	JU3B5214342	390
245 x 392	JU3B5245392	440
307 x 492	JU3B5307492	540
<b>4:3 4cm black borders</b>		
174 x 232	JU3B5174232	280
196 x 262	JU3B5196262	310
219 x 292	JU3B5219292	340
257 x 342	JU3B5257342	390
294 x 392	JU3B5294392	440
369 x 492	JU3B5369492	540
<b>16:9 4 cm black borders + 30cm drop</b>		
130 x 232	JU3B5130232	280
147 x 262	JU3B5147262	310
164 x 292	JU3B5164292	340
192 x 342	JU3B5192342	390
220 x 392	JU3B5220392	440
277 x 492	JU3B5277492	540

Easy to integrate square case

Wire switch included



Remote controls optional p15



Optional



- **MOTOR CUT-OFF SECURITY**
- **EASY TO INTEGRATE**

# ORION JUMBO accessories and options

Caution before fixing to the wall: make sure that the wall will support the weight of the screen.

JUMBO accessories allow several fixing methods:

- Ceiling mounting
- Wall mounting (optional)
- Barrel mounting (optional)

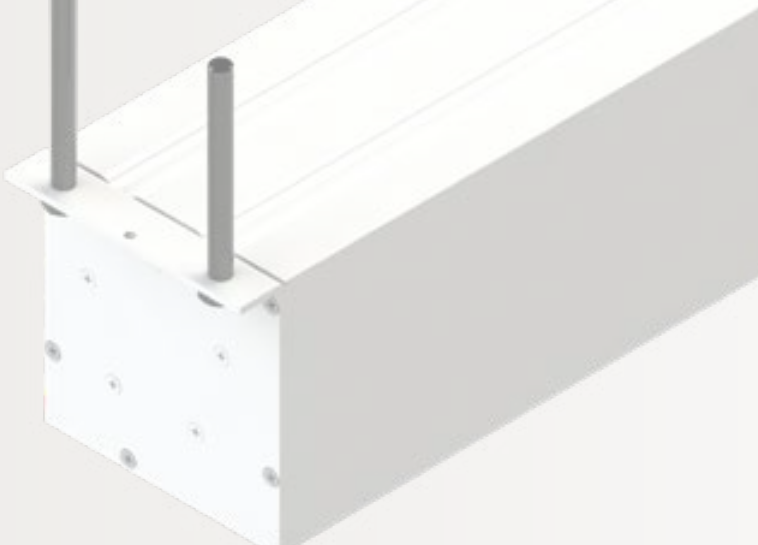

Standard ceiling mounting

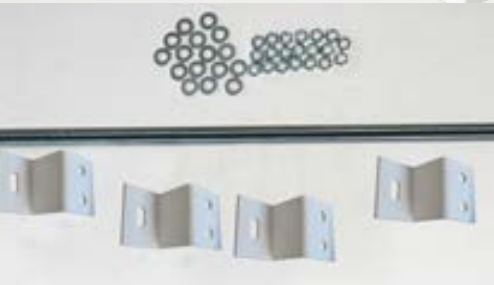

OPTION: Suspended mounting set  
1m threaded rods and fixing brackets

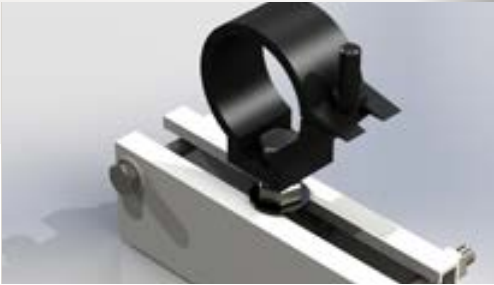

OPTION: Barrel mounting

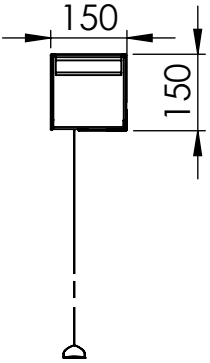

Casing profile  
Power supply on the right

### SUSPENDED MOUNTING

Reference	Quantité
OPTKITOP2	1 kit

### BARREL MOUNTING

Reference	Quantité
PATPERJUM01	The pair

### WALL MOUNTING

Reference	Quantité
PATMURJUM15	The pair

### STAND-OFF BRACKETS

The pair	
Reference	Offset
OPTECAR10JU	10 cm
OPTECAR20JU	20 cm
OPTECAR30JU	30 cm
OPTECAR40JU	40 cm



# IN-CEILING ORION HC OR TENSIONED

The **IN-CEILING ORION** is a all-in-one solution for an easy and aesthetic recessed installation. Easy installation, especially designed to fit any false ceiling.



- The **tensioned version** is the only possible compromise for ultrashort-throw projection if a fixed frame screen is not possible. The lateral cables allow the tensioned projection surface to remain flat regardless of the screen's environment.
- Possibility of customising by printing all or part of the surface of the screen (logo, visual, texts...)



Wire switch included

## IN CEILING ORION HC



Image (cm) Black out Matt White Casing length (cm)

16:10 4cm black borders+ 20cm drop		
145 x 232	OP2B5145232	256
164 x 262	OP2B5164262	286
182 x 292	OP2B5182292	316
214 x 342	OP2B5214342	366
245 x 392	OP2B5245392	417
307 x 492	OP2B5307492	517
4:3 4cm black borders		
174 x 232	OP2B5174232	256
196 x 262	OP2B5196262	286
219 x 292	OP2B5219292	316
257 x 342	OP2B5257342	366
294 x 392	OP2B5294392	417
369 x 492	OP2B5369492	517
16:9 4 cm black borders+ drop noir 30 cm		
130 x 232	OP2B5130232	256
147 x 262	OP2B5147262	286
164 x 292	OP2B5164292	316
192 x 342	OP2B5192342	366
220 x 392	OP2B5220392	417
277 x 492	OP2B5277492	517

## IN CEILING ORION TENSIONED



Image (cm) Black out Matt White Casing length (cm)

16:10 4cm black borders+ 20cm drop		
145 x 232	OP3B5145232	280
164 x 262	OP3B5164262	310
182 x 292	OP3B5182292	340
214 x 342	OP3B5214342	390
245 x 392	OP3B5245392	440
307 x 492	OP3B5307492	540
4:3 4cm black borders		
174 x 232	OP3B5174232	280
196 x 262	OP3B5196262	310
219 x 292	OP3B5219292	340
257 x 342	OP3B5257342	390
294 x 392	OP3B5294392	440
369 x 492	OP3B5369492	540
16:9 4 cm black borders + 30 cm drop		
130 x 232	OP3B5130232	280
147 x 262	OP3B5147262	310
164 x 292	OP3B5164292	340
192 x 342	OP3B5192342	390
220 x 392	OP3B5220392	440
277 x 492	OP3B5277492	540

The weighing bar closes the whole case in raised position

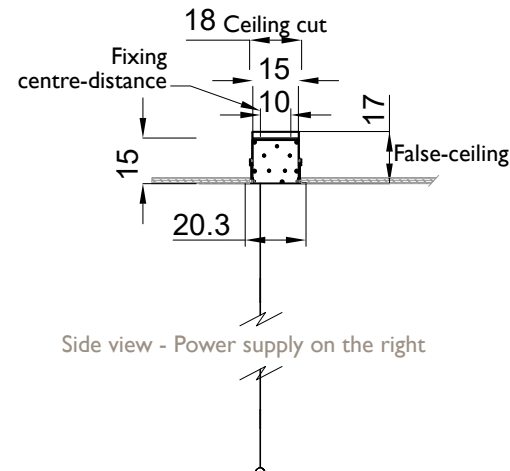

## MOUNTING KIT

Base	Reference
screen < 300 cm	OPKITOP2
screen ≥ 300 cm	OPKITOP3



Remote controls optional p15



Optional



• **INVISIBLE WHEN ROLLED UP**

# PANTOSCREEN WITHOUT CASING

The **PANTOSCREEN WITHOUT CASING** is a recessable electric screen, equipped with a tensioning system at the back, invisible during the projection. It is the solution for a perfect integration in a media furniture, scene,...



Photo credit : © DSR Dark Side of the Room

- Motorised ascending screen
- The horizontal top bar of the screen can support an additional 500g per metre and is equipped with a mechanism for levelling the screen surface.
- Power supply on the right side.

Requires sturdy mounting to prevent tipping



Pantoscreen without casing

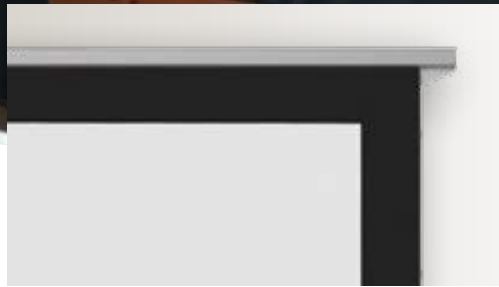

Upper bar

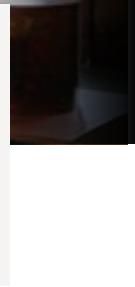

Wire switch included

**PANTOSCREEN WITHOUT CASING HC**  
Black out Matt white fabric.  
4 cm black borders.







**PANTOSCREEN WITHOUT CASING TENSIONED**  
Black out Matt white fabric.  
4 cm black borders.



Tensioning system at the back





 Remote controls optional p15  

 Optional



- WITHOUT CASING
- INVISIBLE TENSIONING SYSTEM AT THE BACK



# PANTOSCREEN WITH CASING

The **PANTOSCREEN WITH CASING** screen is equipped with a housing and a pantograph mechanism at the back. White aluminium casing as standard. Motorised ascending screen.



- **Footless Pantoscreen:** requires a robust fixing to prevent tipping.
- **Pantoscreen with feet:** in option.
- An HC version with black borders can be produced

Never open the screen unless it is firmly attached to its stand or its feet



Casing

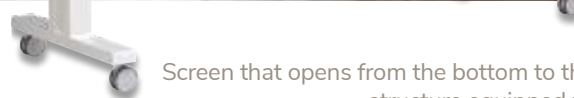

## OPTION ON FEET

Screen that opens from the bottom to the top, with a supporting structure equipped with 4 wheels, for places where it is impossible to fix a screen.



Wire switch included

## PANTOSCREEN WITH CASING HC

Black out Matt white fabric. 4 cm black borders.



## PANTOSCREEN WITH CASING TENSIONED

Black out Matt white fabric. 4 cm black borders.



Invisible tensioning system at the back



Remote controls optional p15



Optional



- **INVISIBLE TENSIONING SYSTEM AT THE BACK**
- **NOMADIC: ON FEET**

# REMOTE CONTROLS

**INFRARED**



Ref. OPTCOMIRHOME1

Infrared receiver + infrared remote control.

**KEY SWITCH**



Ref. OPTINTERCLE

Momentary position Key switch. Can be associated to a wired inverter.



Réf : 6AMP0737

Fixed position key switch. Cannot be associated to another inverter.

**RADIO TRIGGER**



Ref. OPTCOMTRIG1

Radio TRIGGER Open the screen when switching on the videoprojector. Compatible with videoprojector equipped with IEC C13 cable.

**RADIO ORAY**



Ref. OPTCOMMANDRAD8

Radio receiver + remote control  
The receiver has a free terminal block for dry contacts.



Ref. 1MOT03083

1 channel remote



Ref. 1MOT03084

6 channels remote



Ref. OPTCOMMANDRAD9

Radio receiver + HF wall switch.  
Additional HF wall switch.  
1MOT03085



Ref. 1MOT03086

Wired wall transmitter integrating a radio receiver function.

**RADIO SOMFY**



Ref. OPTCOMMANDRAD3

Radio receiver + remote control



Ref. OPTCOMMANDRAD4

Radio receiver + HF wall switch



Ref. 1MOT03041

Receiver only



Ref. 1MOT03016

Wall-mounted switch to be associated with a radio receiver.



Ref. 1MOT03011

Portable transmitter to be associated with a radio receiver.



Ref. : 1MOT03013

4-channel transmitter to control up to 4 devices to be associated with a radio receiver.

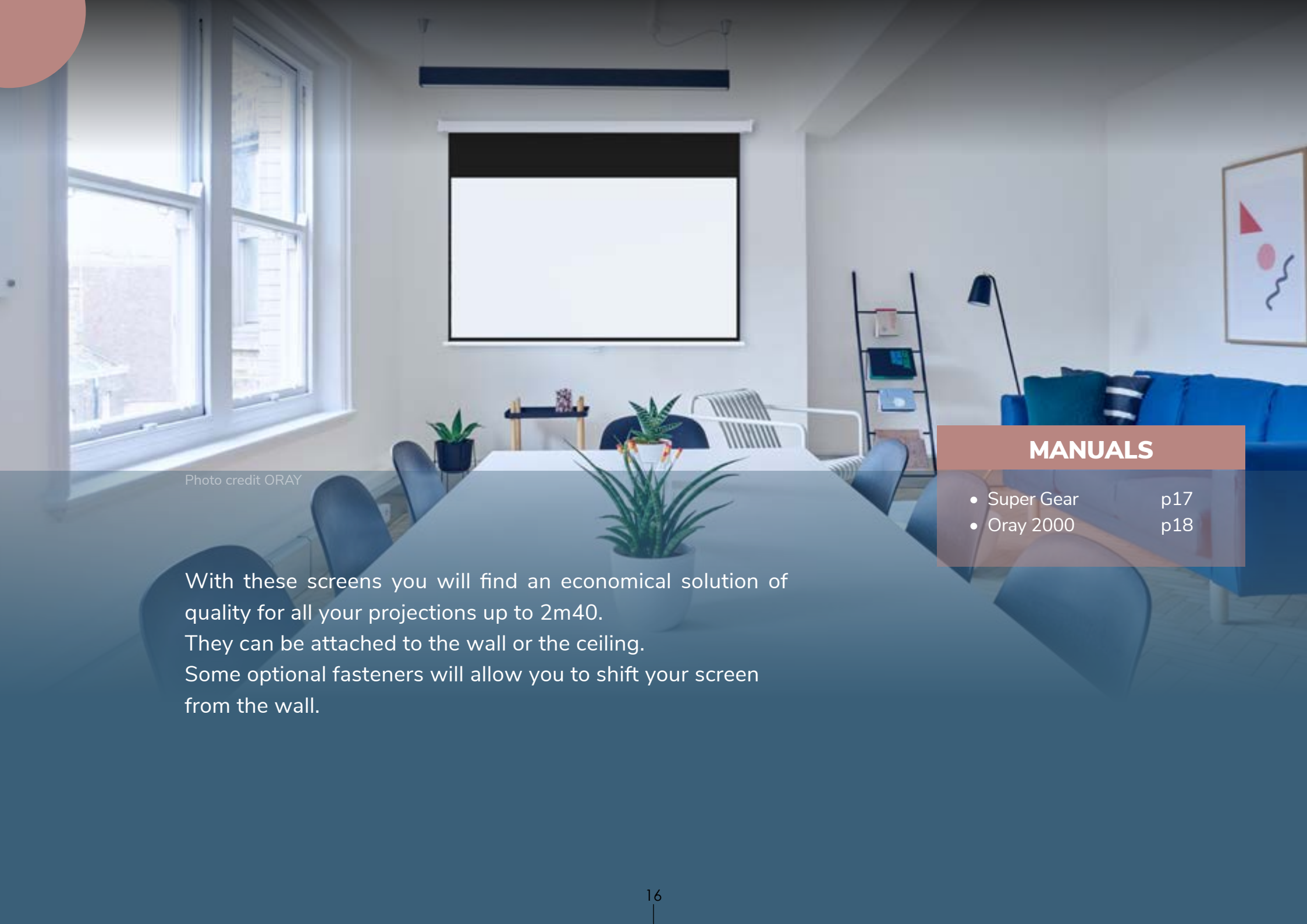

Photo credit ORAY

With these screens you will find an economical solution of quality for all your projections up to 2m40. They can be attached to the wall or the ceiling. Some optional fasteners will allow you to shift your screen from the wall.

## MANUALS

- Super Gear p17
- Oray 2000 p18

# SUPER GEAR

The **SUPER GEAR** screen is equipped with an aluminum case which design is very modern.

Photo credit ORAY

- New SRS (Slow return system) stopping device which controls the progressive rising up of the weighing bar.
- Sliding wall/ceiling mounts.



Case with white epoxy finish



Super Gear HC

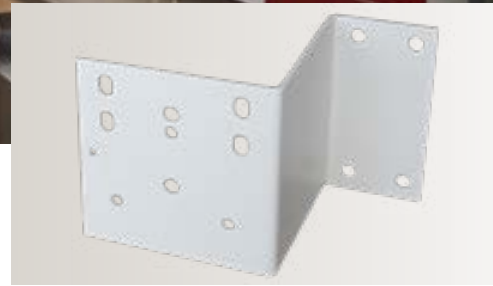

OPTION Stand-off brackets

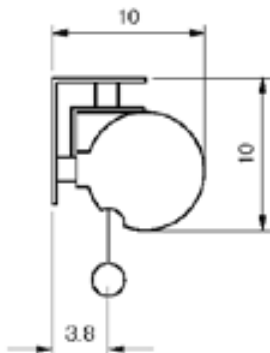

## SUPER GEAR HC



Image format Ht x Base (cm)	Black out Matt white	 Casing Length (cm)
<b>4:3 format 4 cm black borders</b>		
174 x 232	MPP09B1180240	250
<b>16:10 format 4 cm black borders+ 20 cm drop</b>		
108 x 172	MPP09B1112180	190
120 x 192	MPP09B1125200	210
145 x 232	MPP09B1150240	250
<b>16:9 format 4 cm black borders+ 30 cm drop</b>		
97 x 172	MPP09B1101180	190
108 x 192	MPP09B1112200	210
130 x 232	MPP09B1135240	250

## STAND-OFF BRACKETS

The pair	Reference
10 cm	OPTECAR10
20 cm	OPTECAR20
30 cm	OPTECAR30
40 cm	OPTECAR40



- ANY HEIGHT STOP
- SLOW RETURN SYSTEM
- SLIDING BRACKETS



# ORAY 2000

The **ORAY 2000** is a manual screen with a white lacquered steel housing. It is equipped with a spring roller for silent operation.

Photo credit ORAY



- Wall or ceiling mounting brackets are integrated into the ends of the screen.
- It has a stop device on its whole height (approximately every 10 cm).



White lacquered steel casing

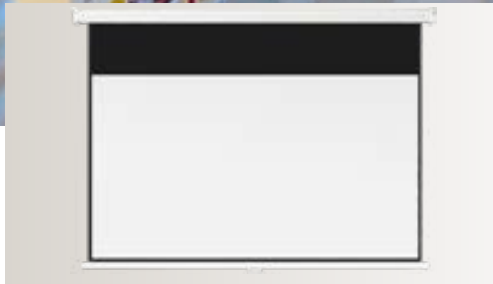

Oray 2000 HC

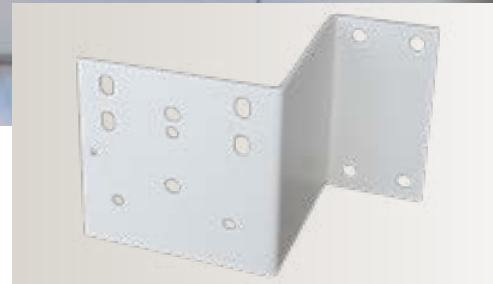

OPTION Stand-off brackets

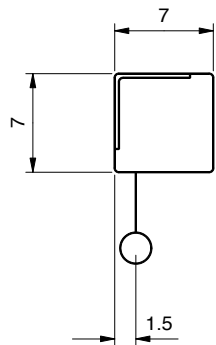

## ORAY 2000 HC



Image format Ht x Base (cm)	Black out Matt white	Casing Length (cm)
<b>4:3 format</b>	<b>4 cm black borders</b>	
144 x 192	MPP02B1150200	213
<b>16:9 format</b>	<b>4 cm black borders+ 30 cm drop</b>	
97 X 172	MPP02B1101180	193
108 X 192	MPP02B1112200	213
130 X 232	MPP02B1135240	253

## STAND-OFF BRACKETS

The pair	Reference
10 cm	OPTECAR10
20 cm	OPTECAR20
30 cm	OPTECAR30
40 cm	OPTECAR40



- ECONOMIC
- ANY HEIGHT STOP





We present here a range both aesthetic and original, adapting to all your travelling constraints. Easy to set up, these screens are available in different formats.

## NOMADS

- Butterfly mobile p 20
- Fly p 21
- Dragonfly, Cross Screen, Miniscreen p 22
- Style, Byron 2, Screen p 23

# BUTTERFLY MOBILE

Ever more compact, the **BUTTERFLY MOBILE** is the fastest opening screen on the market. Ideal for rental or private use, up to 2m40 base.

- On both ends of the case of the screen, there is two large wheels that make it easy to carry around.
- The case design, fully made in aluminum, offers an efficient protection of the screen while carrying it around.
- Lift the top bar to open it instantly, thanks to the pantograph mechanism.



Wheels at the ends



Carrying handle



Pantograph mechanism

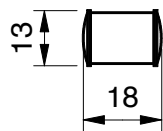

Large casing for 236 cm base models

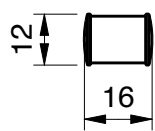

Small casing

## BUTTERFLY MOBILE



Image format Ht x Base (cm)	Black out Matt white	Casing Length (cm)
<b>4:3 format 2 cm black borders</b>		
117 x 156	BUT02B1120160	180
132 x 176	BUT02B1135180	200
147 x 196	BUT02B1150200	222
177 x 236	BUT02B1180240	262
<b>16:9 format 2 cm black borders + drop</b>		
110 x 196	BUT02B1112200	222
133 x 236	BUT02B1135240	262
<b>1:1 format 2 cm black borders</b>		
196 x 196	BUT02B1200200	222



- QUICK RELEASE
- WHEELS AT THE ENDS



# FLY

FLY is a generation of simple mobile screens, compacts and robusts.

Available in 2 versions:

- Fly Mono: Single front projection
- Green Fly : Green background for inlay



Fly Mono



Green Fly



Telescopic upright

- The height is adjustable thanks to a telescopic upright and a tilting device ensures parallax compensation.
- A tensioning device has been specially designed to hold the screen surface taut and wrinkle free.
- The opaque projection surface bears black borders.
- Matt white screen gain: 1.1

## FLY MONO



Single side front projection, black aluminum case.

Image format Ht x Base (cm)	Black out Matt white	 Casing Length (cm)
<b>16:10 format 2 cm black borders</b>		
97,5 x 156	FLY01B1100160	170
110 x 176	FLY01B1112180	190
122,5 x 196	FLY01B1125200	210

## GREEN FLY



Green background for inlay, black aluminum case.

Image format Ht x Base (cm)	Green fabric	 Casing length (cm)
<b>Special format</b>		
220 x 180	FLY01VV220180	190
220 x 200	FLY01VV220200	210



- DESIGN
- MULTI-FORMAT
- LIGHTWEIGHT





# DRAGONFLY CROSS SCREEN MINISCREEN

The **DRAGONFLY** at the tip of innovation represents the entire know-how of ORAY in terms of mobile screens.

The **MINISCREEN** is a portable screen, ultra-light, very easy to use specially developed for Picoprojectors, to be placed on a table.

The **CROSS SCREEN** is an ultraportable screen that gets easily and quickly assembled and disassembled while offering a wide projection surface.

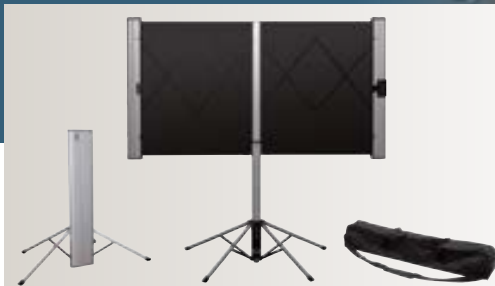

DRAGONFLY: Horizontal pantograph system



CROSS SCREEN: lightweight



MINISCREEN Open feet

## DRAGONFLY



Multi-formats screen thanks to its pantograph system and horizontal opening.

- Easily carried around with its reinforced transport bag.
- Its 4-feet stand makes it very stable.
- The innovative horizontal opening offers a large screen that can fold back lengthwise, which reduces its bulkiness.

## CROSS SCREEN



With its transport bag, the CrossScreen is particularly adapted to nomadic presentations. Installed in a few minutes:

- Easy and very quick to set up
- Adjustable in height
- Can be fixed to the wall

## MINISCREEN



Ultra lightweight portable screen, very simple to set. It is dedicated to pico projectors and can be placed on a table.

- The black anodized aluminum housing combines lightness and quality.
- The fabric is tensioned thanks to an upright placed at the back of the casing.
- Easy to open in few seconds for your presentations to a wide audience in any circumstance.

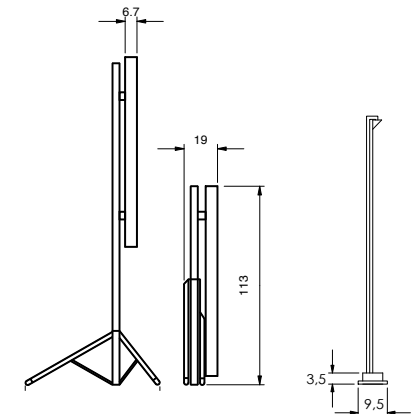

Dragonfly

Miniscreen

Image format Ht x Base (cm)	Black out Matt white Reference
<b>3 formats in 1: 4:3, 16:10 and 16:9</b>	
101 x 134/ 162 /180	DRA01B1101180

Image format Ht x Base (cm)	Black out Matt white Reference
<b>16:9 format</b>	
75 x 133	CS1B1075133
87 x 155	CS1B1087155
100 x 177	CS1B1100177
112 x 200	CS1B1112200

Image format Ht x Base (cm)	Black out Matt white Reference
<b>4:3 format 2 cm side borders</b>	
79 x 102	MIN01B1079102



- TRANSPORT BAG
- COMPACT
- LIGHTWEIGHT

# STYLE BYRON2 SCREEN

Tripods remain the must-have products in the institutional market and general public.

From the Style, the most robust tripod of the market, to the Screen more intended to personal use, this range meets your needs for mobility and resistance.



Very robust and extremely easy to use. They are the ideal compromise for all projections that just need temporary installation.



SCREEN Telescopic upright

BYRON 2: White back  
SCREEN: Black back

STYLE 5 wheels foot

STYLE tripod



OPTION Transport bag for tripods

## SCREEN



Small dimensions and easy to use, these screens are consumer-grade products. Black lacquered steel casing.

## STYLE



White lacquered aluminium casing perfectly resistant to torsion.

- Supplied with a tiltable stem for parallax correction.
- Ultra robust handle.

## BYRON 2



Black lacquered steel casing  
Fire resistant matt white projection surface (M1)

Reference	Casing length (cm)
HOUSV2BYR150	150
HOUSV2BYR180	180
HOUSV2BYR200	200
HOUSV2BYR240	240

Image format Ht x Base (cm)	Black out Matt white Reference
<b>1:1 format</b>	
125 x 125	TRE03B1125125
150 x 150	TRE03B1150150
175 x 175	TRE03B1175175

Image format Ht x Base (cm)	Matt white Tripod	Matt white Wheels foot
<b>4:3 format</b>		
180 x 240	TRE06B1180240	
<b>1:1 format</b>		
150 x 150		PIE06B1150150
180 x 180		PIE06B1180180
200 x 200		PIE06B1200200
230 x 230	TRE06B1230230	

Image format Ht x Base (cm)	Matt white Reference
<b>1:1 format</b>	
150 x 150	TRE02B1150150
180 x 180	TRE02B1180180
200 x 200	TRE02B1200200



- CLASSIC
- POWERFUL





These screens meet all your requirements.

Aesthetics and recessing features, flat surfaces and robustness, for all markets.

Easy to install, the aluminum frames come with a projection surface fixed with snap buttons or eyelets thus making mounting and dismounting easy.

No matter your architectural constraints, we are at your disposal for made to measure manufacturing of straight or arched frames and specific mounting devices.

## FRAMES

- Special video p 25
- Cadre HC p 26
- Cineframe p 27
- Cineframe UST-ALR p 28
- Le Mask p 29
- Cinevision I p 30

# SPECIAL VIDEO

The **SPECIAL VIDEO** is a discreet screen with a thin profile that leaves the focus to the projection. Easy to assemble, without tools!



- Rigid, design and easy to assemble,
- Avoids the projection of shadows on the image.
- The whole system can be assembled in a few minutes without any special tools. The frame is easily set up and locked automatically.
- The screen fabric is fixed at the back of the frame with snap buttons.



Black anodized



Profile of the frame



The screen fabric is fixed with snap buttons

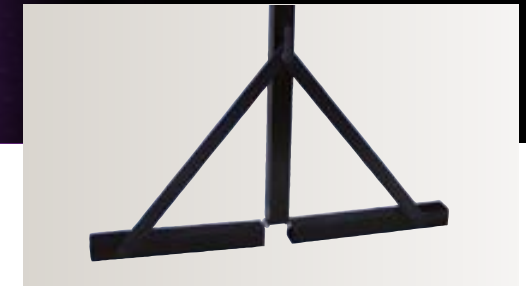

OPTION removable legs: Black anodized feet with parallax compensation.

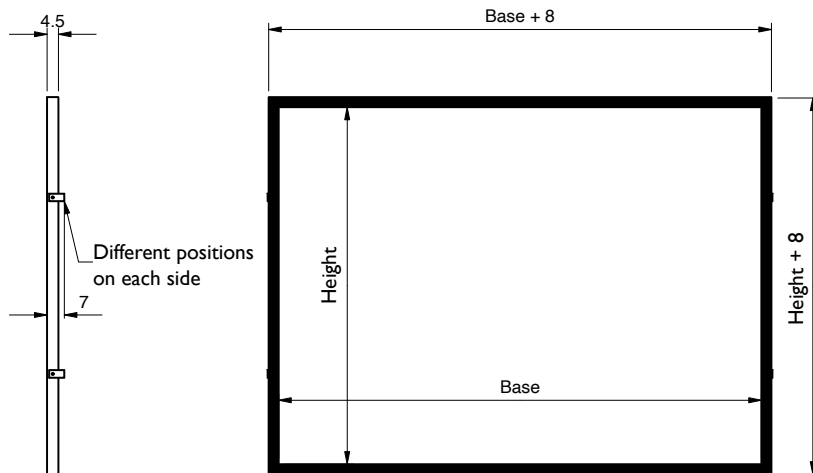

## SPECIAL VIDEO

Image format  
Ht x Base (cm)

### 4:3 format

150 x 200	SP1B1150200
180 x 240	SP1B1180240
202 x 270	SP1B1202270
225 x 300	SP1B1225300
300 x 400	SP1B1300400

### 16:10 format

125 x 200	SP1B1125200
150 x 240	SP1B1150240
169 x 270	SP1B1169270
187 x 300	SP1B1187300
250 x 400	SP1B1250400



Matt white  
Ref.



Other sizes, fabrics, colours, ON REQUEST



- THICKNESS
- LIGHTWEIGHT
- EASY

# CADRE HC

Chic and elegance:  
aluminum frame covered with  
black velvet.

- The projection surface is fixed with snap buttons, totally invisible at the back of the frame.
- Easy to install and adapted to all configurations.
- Overall dimensions: image format + 16 cm



Great rigidity



Black velvet frame



The screen fabric is fixed with snap buttons



Bendable screen

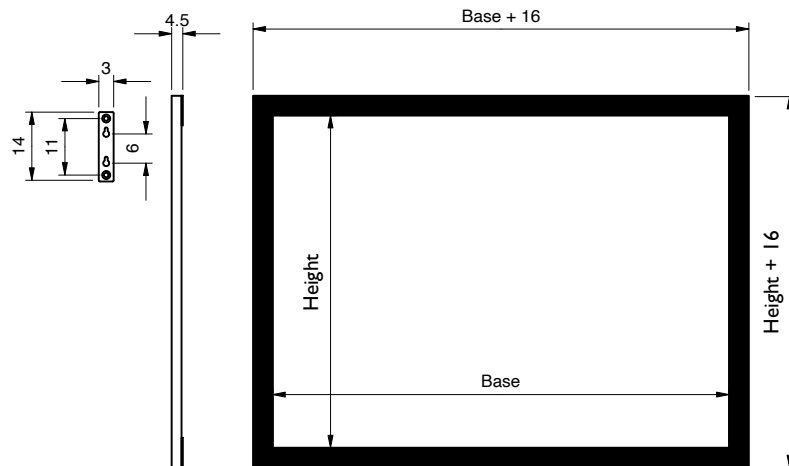

## CADRE HC



Image format Ht x Base (cm) Matt white Ref.

### 16:9 format

112 x 200	CH1B1112200
135 x 240	CH1B1135240
152 x 270	CH1B1152270
169 x 300	CH1B1169300
225 x 400	CH1B1225400

### 16:10 format

125 x 200	CH1B1125200
150 x 240	CH1B1150240
169 x 270	CH1B1169270
187 x 300	CH1B1187300
250 x 400	CH1B1250400

Other sizes, fabrics, colours, ON REQUEST



- FINISH
- REMOVABLE
- LIGHTWEIGHT



# CINEFRAME

The **CINEFRAME** is a screen with a black velvet finish, which ensures it fits perfectly into your Home Cinema.



- Available from stock only in standard sizes.
- The Cineframe is delivered with wall fasteners.
- Easy to install, the frame is suspended, like a picture, with 2 screws located in the upper corners.



Black velvet finish



Fixing on the back



8 cm black velvet frame

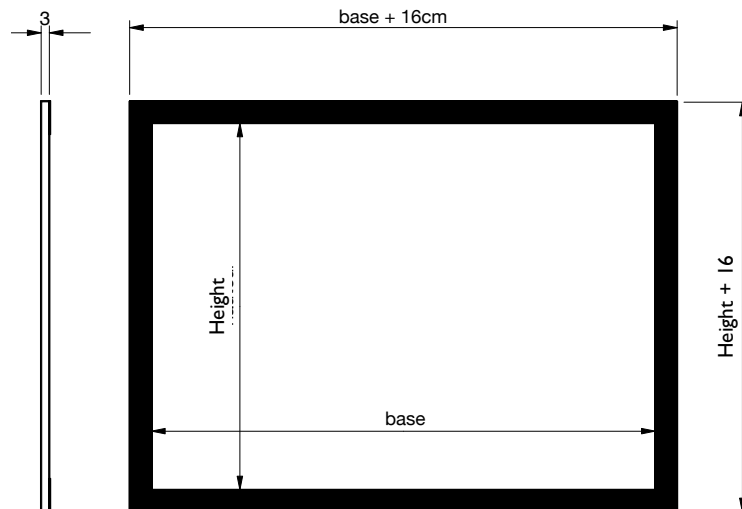

## CINEFRAME



Image format  
Ht x Base (cm)

Matt white  
Ref.

16:9 format	
112 x 200	CIF01B1112200
135 x 240	CIF01B1135240
169 x 300	CIF01B1169300



- FINISH
- EASY TO INSTALL
- ECONOMICAL

# CINEFRAME UST-ALR



- Discreet 1cm black frame
- Perfect tension of the projection surface by means of springs
- Wall mounting
- The projection surface with directional structures directs the light of the video projector exclusively towards the viewer, rejecting all ambient light.

The CINEFRAME UST-ALR is the essential screen for ULTRA SHORT THROW projection!

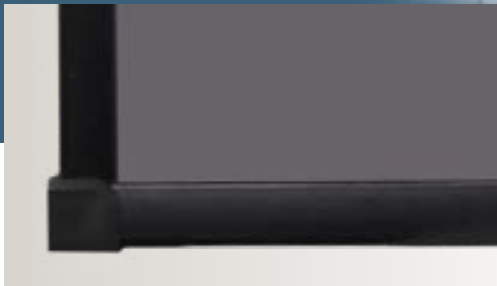

Frame detail



Fabric tensioning system with springs



Grey surface with ambient light rejection

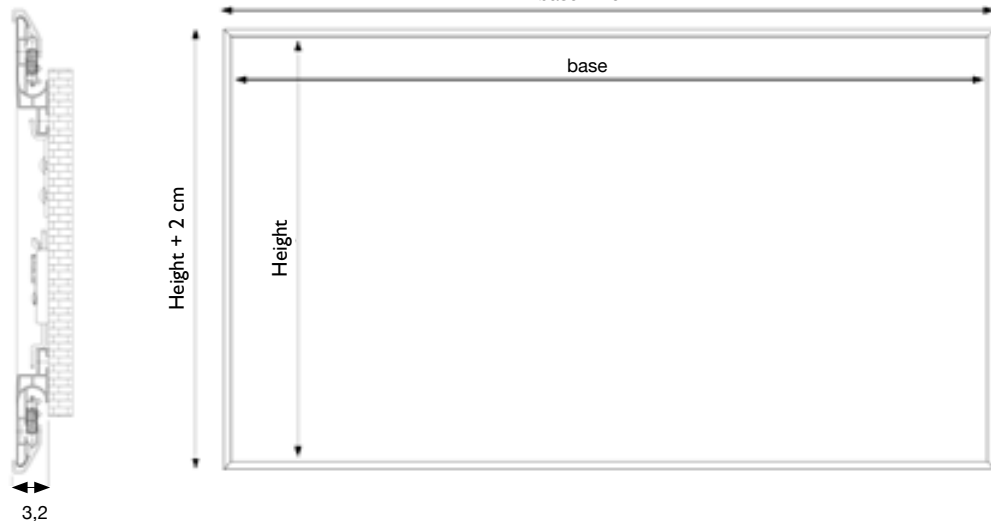

## CINEFRAME UST-ALR



Image format  
Ht x Base (cm)

ALR surface Ref.

16:9 format

124 x 221

CIALR124221

149 x 265

CIALR149265



- ULTRA SHORT THROW
- DISCREET
- AMBIENT LIGHT REJECTION



# LE MASK



For a Home Cinema setting without compromise!  
**LE MASK** is a framed screen with an electric masking system that allows you to adapt to the diffusion format of your movie.

- It is compatible for the following formats: 4:3, 16:9, 2,35:1 and 16:10.
- Perfect integration with its velvet finish.
- Acoustically transparent masking components within a Microperf Oray® fabric.
- The snap buttons fixation ensures a perfect flatness of the fabric.

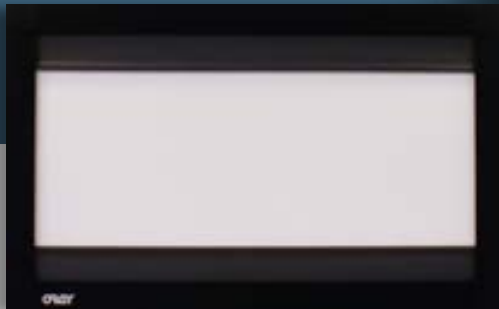

21 cm black velvet frame

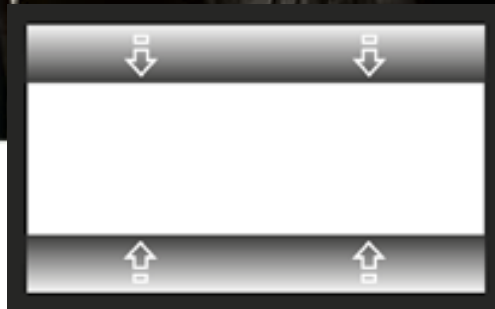

With two horizontal masks: The image base is constant and allows the projection of 3 formats.

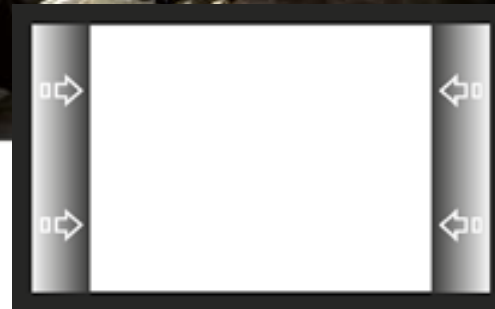

With two vertical masks: The image height is constant and allows the projection of 3 formats.



With two horizontal masks and two vertical masks: The mobile height and base allow the projection of 3 formats.

Your image is always perfectly framed, whatever the format.



## LE MASK

Fully open, the screen format must match the native format of your projector.

Quote on request according to your specs



- MULTI-FORMATS
- INTEGRATION

# CINEVISION I

CINEVISION I is designed for large projection surfaces and adaptable to all movie theaters, it will also suit large conference rooms, communication rooms, show rooms and auditoriums.

- Wall mount or suspended,
- Custom made,
- Available in all dimensions,
- Can be mounted and dismantled as wished,
- Can be fixed at a distance from the wall with optional stand-off brackets.



The projection surface is tensioned with eyelets at the back of the frame.



Quick suspension of the frame on its mounts and locking feature by 45° rotation



## CINEVISION 1



Requested information to make a quote:

- Type of projection surface
- Image format
- Mount type

Quote on request according to your specs



- LIGHT WEIGHT
- LARGE SIZES

Oray manufactures made-to-measure cyclos and special projection surfaces with a wide choice of finishes: eyelet, open hem, snap button, etc.

## CUSTOM-MADE FABRICS

- Projection surfaces p 32
- Finishes p 33

# PROJECTION SURFACES

The FRONT PROJECTION surfaces are made of recyclable PVC.

They can be perforated (acoustic surfaces), or 3D for special applications.

For REAR PROJECTION, surfaces are translucent to allow projection from behind the screen.



Installation © CSGV

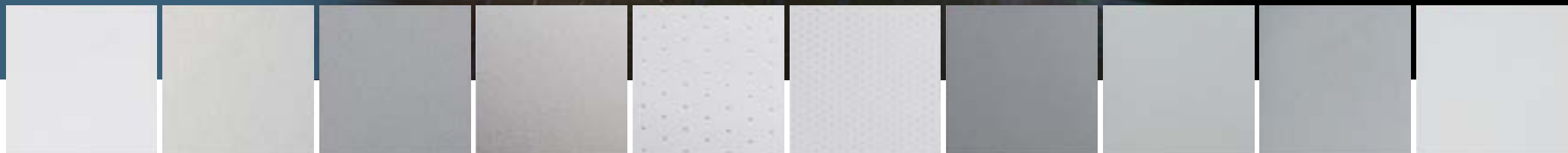

Matt white Special mother-of-pearl Black contrast Metallic 3D Transonore Microperf'Oray Translucent HC Translucent HG Translucent HD Translucent DF

**NEW**



You'll find some of our projection surfaces in their woodsense version, made from up to 92% natural ingredients and 100% recyclable.

- Classified b-s1,d0
- Reduced carbon footprint

## FRONT PROJECTION

- Matt white
- Black out Matt white
- Transonore
- Microperf'Oray
- Microperf'Oray HD 4K
- Special mother-of-pearl
- Metallic 3D
- Black contrast

## REAR PROJECTION

- Translucent HC
- Translucent HG
- Translucent HD
- Translucent DF
- Translucent 3D

## ADHESIVE FILM

- Window displays
- Digital signage
- Projection films
- Holographic ...

The widest and most specialised range of projection films on the market.



- CUSTOMIZED
- FINISHES



# FINISHES



Installation © Nakajima 中島良平



Snap button



Snap buttons on white borders



Eyelet



Open hem

## CONFECTION and KNOW-HOW

ORAY offers a wide range of confections for your made-to-measure projects: snap buttons, eyelets, open hems, round fabrics, etc.

## WIDE-WIDTH HD PRINTING

ORAY customises your fabrics by printing them with a logo, text or image on part or all of the surface.



- CUSTOMIZED
- FINISHES

See all our surfaces in detail at [www.oray.fr](http://www.oray.fr)





Our range of motorised mounts for video projectors offers integration solutions for all your installations.

A wide range of fixed mounts for video projectors and flat screens allows to adapt to all your constraints.

## MOUNTS

### For Video projectors

- Motorised mounts p 35
- Fixed mounts p 36

### For flat screens

- Fixed mounts p 37

# MOTORISED MOUNTS for VIDEO PROJECTORS

Our range of mounts is adapted to all kinds of integration to hide your video projector in the false ceiling.



Recessed installation frame supplied with the mini pantographe 10

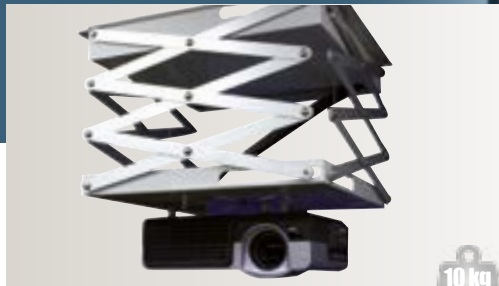

Mini-pantographe 10

10 kg  
maxi



Mini-pantographe 20

25 kg  
maxi



Mirror mount installed in false ceiling



Invisibility of the mirror mount with the frame+cover kit

- Maximum run length: 80 cm
- Maximum load: 10 kg

- Maximum run length: 195 cm
- Maximum load: 25 kg

- Perfect integration
- Invisibility
- Small bulk

## Supplied with:

- Radio remote control (receiver equipped with up/ down buttons)
- Recessed installation frame.

## Supplied with:

- Radio remote control (receiver equipped with up/ down buttons)

## Supplied with:

- Radio remote control



Radio remote control supplied

## MINI-PANTOGRAPHE 10



Reference	Run length
SVP0801	80 cm

## MINI-PANTOGRAPHE 20



Reference	Run length
SVP0601	97,5 cm
SVP0602	195,0 cm

Options
SVPMOPT01 Recessed installation frame.

## MIRROR MOUNT



Reference
SVPM001

Options
SVPMOPT03 Package Frame+Cover



- INTEGRATION
- FINISHING

# FIXED MOUNTS for VIDEO PROJECTORS

For more products,  
please contact us

## FIXED CEILING MOUNTS UNIVERSAL MOUNT

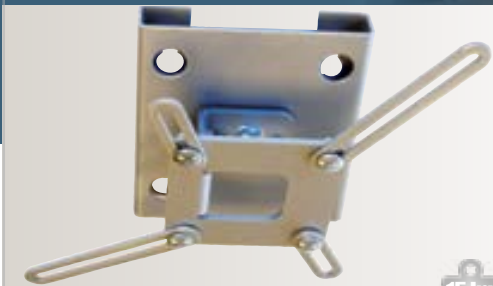

15 kg  
maxi

Short brackets: fixed ceiling mounts

### SHORTS BRACKETS

Direct ceiling mounting

### FIXED CEILING MOUNTS (universal mount)

- Independent adjustment of rotation, tilt and horizontal position
- Maximum load 15 kg
- Available in silver, black or white
- Suitable for most video projectors mounted in reverse position
- Possibility to align image axis to the fixing axis..



15 kg  
maxi

Long brackets: fixed ceiling mount

### LONG BRACKETS

With cable inlay system:

- From 7 cm to 90 cm for SVP005 brackets which can be cut.
- From 7 cm to 150 cm for SVP006 brackets which can be cut.

Reference	Brackets description	Colors
SVP002A	Short	Black
SVP002S	Short	Silver
SVP002B	Short	White
SVP005A	Adjustable (7 to 90 cm)	Black
SVP005S	Adjustable (7 to 90 cm)	Silver
SVP005B	Adjustable (7 to 90 cm)	White
SVP006A	Adjustable (7 to 150 cm)	Black
SVP006S	Adjustable (7 to 150 cm)	Silver
SVP006B	Adjustable (7 to 150 cm)	White

## WALL MOUNTS FOR SHORT THROW



15 kg  
maxi

Wall mount SVP0010

### WALL MOUNTS FOR SHORT THROW PROJECTORS

To be fixed above the screen or the interactive board.

Mounting plate with independent tilting and horizontality adjustments.

- Steel structure
- Maximum load 15 kg

Reference	Description
SVP0010	Short throw VP mount adjustable 75-135 cm



# WALL MOUNTS for FLAT SCREENS

For more products, please contact us



## WALL MOUNTS VESA FROM 75 TO 600 X 400

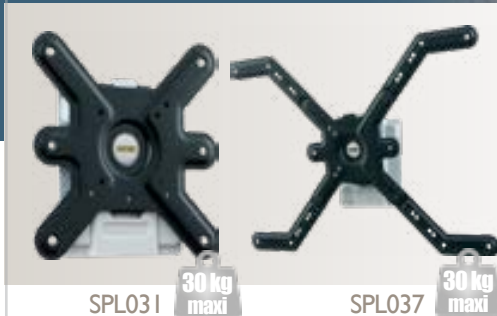

### FIXED

- Ultra slim: 20mm from wall
- Level check for easy installation

Reference	Description	Max. load.
SPL030	Vesa 100	15 kg
SPL031	Vesa 200	30 kg
SPL032	Vesa 400	30 kg
SPL033	Vesa 600	30 kg

### TILTING

- Tilting: +5/-15°
- Level check for easy installation

Reference	Description	Max. load
SPL034	Vesa 100	15 kg
SPL035	Vesa 200	30 kg
SPL036	Vesa 400	30 kg
SPL037	Vesa 600	30 kg

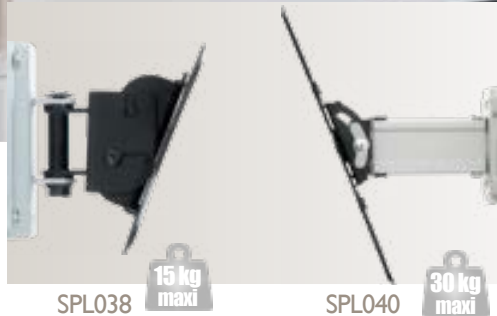

### TILTING AND PIVOTING

- Tilting: +5/-15°
- Twist: see board hereunder
- Level check for easy installation

Reference	Description	Offset	tilting pivoting	Charge max.
SPL038	Vesa 100TW45	99mm	+25°/-25°	15 kg
SPL039	Vesa 200TW45	99mm	+20°/-20°	30 kg
SPL040	Vesa 400TW45	255mm	+40°/-40°	30 kg
SPL041	Vesa 100TW90	244mm	+65°/-65°	15 kg
SPL042	Vesa 200TW90	255mm	+60°/-60°	30 kg
SPL043	Vesa 400TW90	375mm	+65°/-65°	30 kg



Ref.: SPL025, 26, 27

### UNIVERSAL MOUNTS FOR LARGE SIZE FLAT SCREENS: Ultra thin, for LED screens

#### SPL025, 26 and 27

- Extra-flat: the screen is as close to the wall as possible: 16 mm
- Steel wall plate and screen mount.
- Eccentric washer system to correct drilling errors
- Anti-tear system of the screen
- Built-in spirit level - Allows you to check the horizontality of the support when drilling

Reference	Fixation	Offset	Max. load
SPL025	Vesa 75-200	16mm	50kg
SPL026	Vesa 200-400	16mm	60kg
SPL027	Vesa 200-600	16mm	70kg



Ref.: SPL028

#### SPL028 and 29

- Steel wall plate and screen support
- Eccentric washer system to correct drilling errors
- Anti-tear system of the screen
- Tilttable 0°-25°
- Level check for easy installation

Reference	Fixation	Orientation	Max. load
SPL028	Vesa 200 - 400	non	30 kg
SPL029	Vesa 200 - 400	+ / - 90°	30 kg



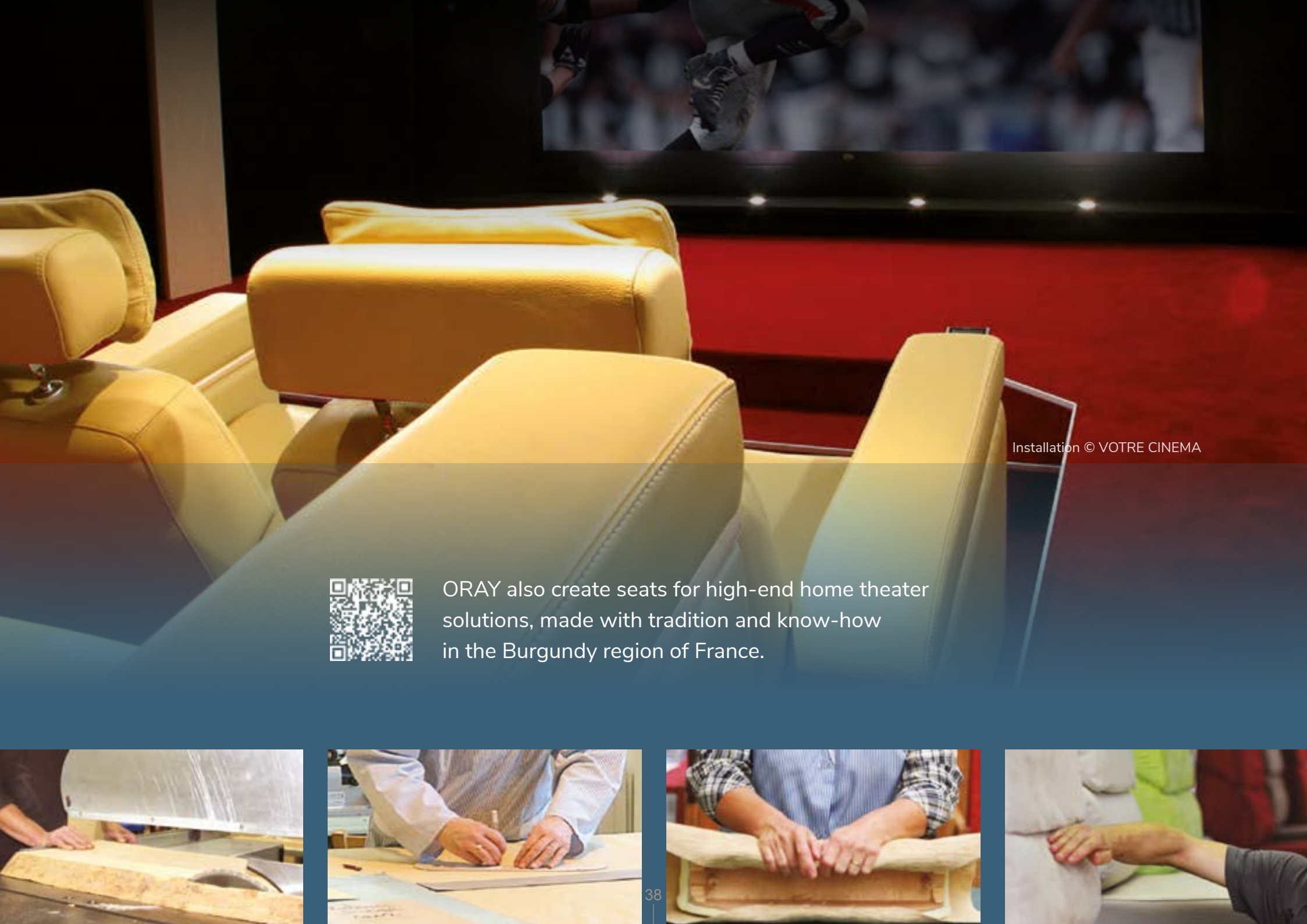

Installation © VOTRE CINEMA



ORAY also create seats for high-end home theater solutions, made with tradition and know-how in the Burgundy region of France.







ORAY  
Chemin de Beaurepaire  
91410 DOURDAN - FRANCE  
Tel +33 (0)1 64 59 94 54  
[www.oray.fr](http://www.oray.fr)