

ORAY

STAGES AND EVENTS

———— 2024 Edition ————



HOME CINEMA AND RESIDENTIAL

projection screens
videoprojectors mounts
flat screens mounts



PROFESSIONAL AND OFFICES

projection screens
videoprojectors mounts
flat screens mounts



STAGES AND EVENTS

projection screens
cycloramas

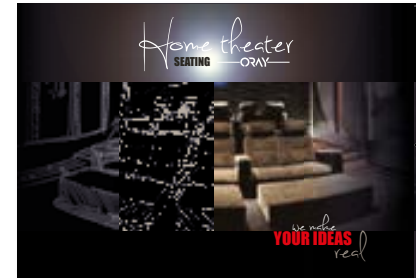

HOME CINEMA SEATS

individual seats
custom-made rows
D-BOX Technology



Our range of STAGES and EVENTS screens

ORAY COMPANY

p 4

ROLL-UP

p 5

GFO

p 6

Polichinelle

p 7

Infiny

p 8

FRAMES

p 9

Cinevision I

p 10

Cinevision II

p 11

Special frames

p 12

CUSTOM-MADE FABRICS

p 13

Projection surfaces

p 14

Finishes

p 15

NOMADS

p 16

Nomaddict 1 and 2

p 17

Cin'Air

p 19

Butterfly mobile

p 20

Fly

p 21

Dragonfly, Cross Screen,

Miniscreen

p 22



This catalogue is printed on paper from responsible sources and sustainably managed forests.



FIRE RESISTANT CLASSIFICATION
Classification of the projection surface.



CUSTOMIZABLE
You can choose another projection surface or ask for a product adapted to your needs.



ADJUSTABLE HEIGHT



ANY HEIGHT STOP
The screen can stop at several heights.



ULTRA SHORT THROW
Model compatible with an Ultra Short Throw video projector



CASING COLOR RAL
Other color maps on request, according to the references of RAL colour.



QUALITY Know-how since 1947

The company ORAY, based south west of Paris, is dedicated to:

- The DESIGNING
- The MANUFACTURING
- The MARKETING

of projection screens and audiovisual accessories.

TECHNOLOGY WATCH N°1 in France

The most exhaustive range
Through continuous search of new products and the wish to adapt as closely as possible to the technical developments of projection, the company is the number 1 in France in the industry of projection screens and is one of the leaders worldwide.

SUSTAINABLE DEVELOPMENT Eco-socio-conception

Social and environmental issues are a priority for ORAY. These commitments led the company to engage several actions in order to improve its global performance in a forward-looking business model:

- ECONOMICAL performance
- SOCIAL performance
- ENVIRONMENTAL performance

Keen to offer the best value for money on the whole range, ORAY takes special care of the choice of materials, the quality of the assembly and the innovative product designs.

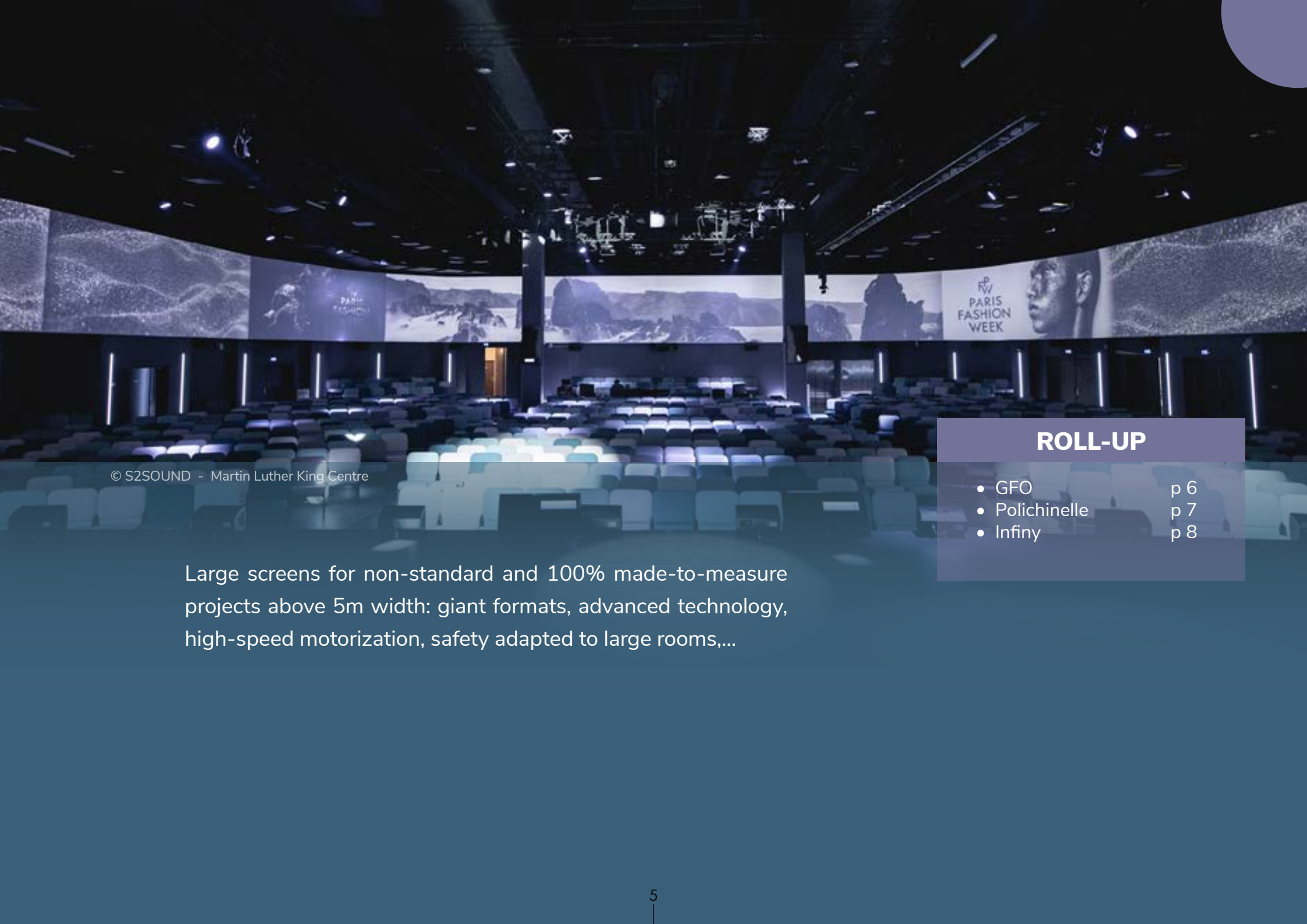

© S2SOUND - Martin Luther King Centre

Large screens for non-standard and 100% made-to-measure projects above 5m width: giant formats, advanced technology, high-speed motorization, safety adapted to large rooms,...

ROLL-UP

- GFO p 6
- Polichinelle p 7
- Infiny p 8

GFO

The **GFO** screens are the natural complement of Orion screens to equip high capacity conference rooms.

The GFO is easy to install and very compact.

The overall length of its housing is only 16,5 cm more than the image format.



- Casing with white epoxy finish.
- Screen fitted with the patented roller counterbalance mechanism to prevent bending.
- Safety brake certified DIN-EN-13241
- Motor power: 350 W
- Diameter of the mechanism : 15 cm
- Weighing bar diameter: 3.4 cm
- Ceiling mount in standard
- Can be recessed in ceiling with under-face option
- Up to 8 m base



OPTION Underface for embedding



OPTION Barrel mount.
Reference (The pair) PATPERGFO



OPTION
Wall mount with or without offset



SUPPLIED AS STANDARD Ceiling mount

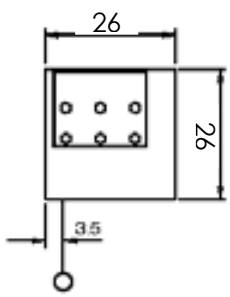

26x26 casing profile
up to 7m base
Power supply on the right

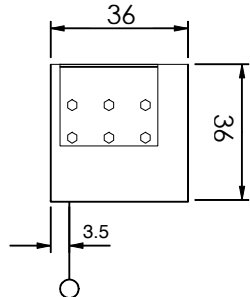

36x36 casing profile
between 7m and 8m base
Power supply on the right



Quote on request according to your specs



Remote controls
optional



- EASY INSTALLATION
- COMPACT
- ANTI-BENDING SYSTEM

POLICHINELLE

The **POLICHINELLE** screens fits in the category of equipments for large auditoriums, conference centers and theatres. They are custom made for all formats with an image base from 7 meters up to 20 meters and more.



Carthage Festival, Tunisia
Photo credit: Cinelec

- The materials used ensures lightness and reliability to the whole system
- Aluminum structure covered with black fabric
- Roller tube in aluminium or carbon fiber for the largest sizes
- No arms in the lower part
- High rigidity
- Easy installation
- Voltage : 230V
- Power supply in the centre of the screen
- Security brake in case of power cut
- Can be mounted on a boom or suspended
- Stop-fall device in option





Winding tube



Barrel mount



2 possible motorisations:

Standard  or High speed 



Somfy transmitter and receiver included

The advantages of the HIGH SPEED version

- The motor can work continuously without thermal cut-off
- Wattage : from 1 to 1.8 kW
- Rolling and unrolling speed : 0.5m/s
- Acceleration and deceleration are controlled to avoid coughs
- In case of power cut, end-stops are kept in memory
- Initial programming from a computer with saved data.
- End-stops are set at the installation site with a radio remote control.



Quote on request according to your specs



- LIGHTWEIGHT
- VERY LARGE DIMENSIONS
- FLATNESS

INFINY

Infiny is a range of large and very large roll-up screens without limits except those of the room in which they are installed.



Its revolutionary ultra simple assembly requires almost no tools. An anti-arrow device allows to guarantee perfect straightness of the tube to ensure an excellent flatness, even on giant screens.



Barrel mounting



Somfy transmitter and receiver included



NEW

Its innovative design offers 3 possibilities adapted to the uses and installation constraints.

1. Delivered in 2m modules for easy handling in case of difficult access or for a mobile installation requiring frequent assembly and disassembly.
2. One-piece delivery of the pre-mounted and factory-adjusted screen. (only for formats under 13m)
3. Delivery in multiple pieces of long lengths if larger than 13 meters base.

Its 220V motorisation is equipped with 2 adjustable stroke ends.
Standard mounting: clamps for 50mm pole

Quote on request according to your specs



- VERY LARGE ELECTRIC SCREEN
- FABRIC FLATNESS SYSTEM



These screens meet all your requirements. Aesthetics and recessing features, flat surfaces and robustness, for all markets.

Easy to install, the aluminum frames come with a projection surface fixed with snap buttons or eyelets thus making mounting and dismounting easy.

No matter your architectural constraints, we are at your disposal for made to measure manufacturing of straight or arched frames and specific mounting devices.

FRAMES

- Cinevision I p 10
- Cinevision II p 11
- Special frames p 12

CINEVISION I

CINEVISION I is designed for large projection surfaces and adaptable to all movie theaters, it will also suit large conference rooms, communication rooms, show rooms and auditoriums.

- Wall mount or suspended,
- Custom made,
- Available in all dimensions,
- Can be mounted and dismantled as wished,
- Can be fixed at a distance from the wall with optional stand-off brackets.



Millau Museum



The projection surface is tensioned with eyelets at the back of the frame.

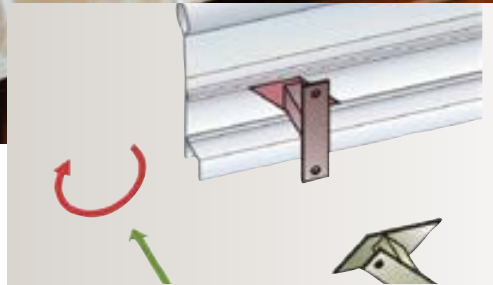

Quick suspension of the frame on its mounts and locking feature by 45° rotation



Millau Museum



CINEVISION 1



Requested information to make a quote:

- Type of projection surface
- Image format
- Mount type
- All details related to the installation

Quote on request according to your specs



- LIGHT WEIGHT
- LARGE SIZES

CINEVISION II

CINEVISION II is a screen with a revolutionary lacing of the fabric and black velvet frame for your large sizes.



Shangri-La Hotel Beijing - China

- Large aluminum profile for rigidity and masking of the fabric fixation.
- Tensioning device of the fabric easy to use.
- Wall mount or suspended,
- Custom made,
- Available in all dimensions,
- Black velvet frame width 21cm.

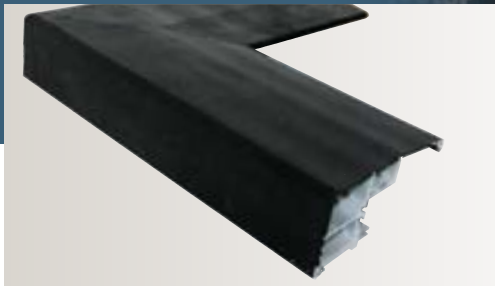

Aluminum frame covered with black velvet



Screen surface tensioning system.

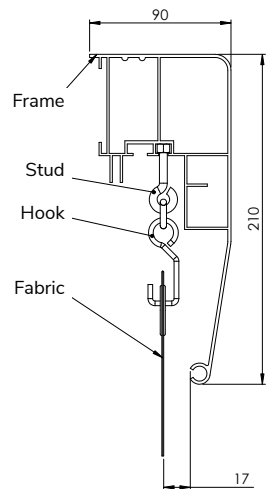

CINEVISION II



Requested information to make a quote:

- Type of projection surface
- Image format
- Mount type
- All details related to the installation

Quote on request according to your specs



- RIGIDITY
- AESTHETICS

SPECIAL FRAMES

Simulators, event, we are at your disposal to study your wildest projects.

- Simulators,
- Amusement park,
- Event
- Museography.

We manufacture spherical, conical, circular (...), screens of any size.

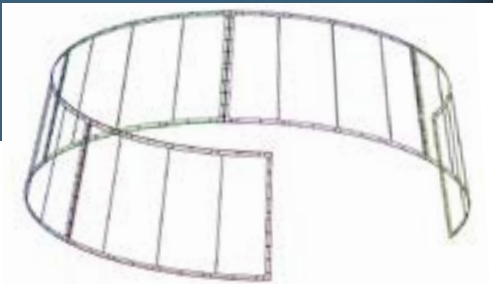

3D Structure



"Carte postale" conical screen 54 meters.
World Expo Shanghai - China



Arched screen for simulator



Requested information to make a quote:

- Type of projection surface
- Image format
- Mount type
- All details related to the installation

Quote on request according to your specs



• ENGINEERING
DEPARTMENT

Oray manufactures made-to-measure cyclos and special projection surfaces with a wide choice of finishes: eyelet, open hem, snap button, etc.

CUSTOM-MADE FABRICS

- Projection surfaces p14
- Finishes p15

PROJECTION SURFACES

The FRONT PROJECTION surfaces are made of recyclable PVC.

They can be perforated (acoustic surfaces), or 3D for special applications.

For REAR PROJECTION, surfaces are translucent to allow projection from behind the screen.



Installation © CSGV

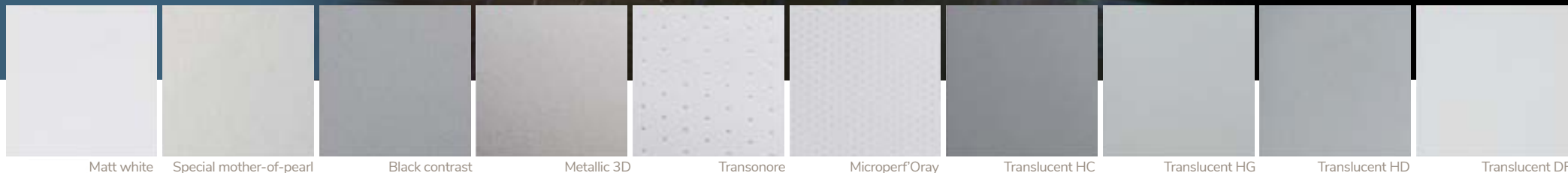

Matt white Special mother-of-pearl Black contrast Metallic 3D Transonore Microperf'Oray Translucent HC Translucent HG Translucent HD Translucent DF

NEW



You'll find some of our projection surfaces in their woodsense version, made from up to 92% natural ingredients and 100% recyclable.

- Classified b-s1,d0
- Reduced carbon footprint

FRONT PROJECTION

- Matt white
- Black out Matt white
- Transonore
- Microperf'Oray
- Microperf'Oray HD 4K
- Special mother-of-pearl
- Metallic 3D
- Black contrast

REAR PROJECTION

- Translucent HC
- Translucent HG
- Translucent HD
- Translucent DF
- Translucent 3D

ADHESIVE FILM

- Window displays
 - Digital signage
 - Projection films
 - Holographic ...
- The widest and most specialised range of projection films on the market.



- CUSTOMIZED
- FINISHES

FINISHES



Installation © Nakajima 中島良平



Snap button



Snap buttons on white borders



Eyelet



Open hem

CONFECTION and KNOW-HOW

ORAY offers a wide range of confections for your made-to-measure projects :
snap buttons, eyelets, open hems, round fabrics, etc.

WIDE-WIDTH HD PRINTING

ORAY customises your fabrics by printing them with a logo, text or image on
part or all of the surface.



- CUSTOMIZED
- FINISHES

See all our surfaces in detail at www.oray.fr



These large screens are indispensable for all your events and for rental purposes. They offer you large images, easy to install and to carry.

NOMADS

- Nomaddict I and 2 p17
- Cin'Air p19
- Butterfly mobile p20
- Fly p21
- Dragonfly, Crossscreen, Miniscreen p22

NOMADDICT 1 AND 2

The **NOMADDICT 1** is the ideal screen for temporary installations.

It comes with a very light and durable ABS carrying case with wheels.

The **NOMADDICT 2** is suitable for larger sizes.



Flight case equipped with wheels

2 standard versions are available:

- **Matt white** : a matt white surface with white or black edges.
- **Duo** (delivered with 2 fabrics): a Matt white surface with white or black borders and a translucent surface with black borders.

For other surfaces, please contact us.

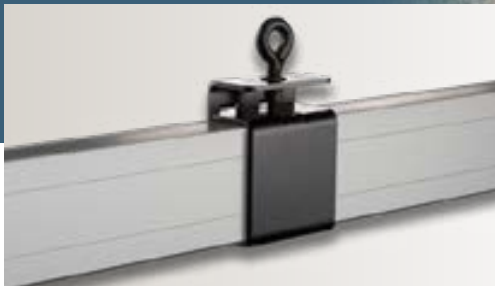

Suspension hook

NOMADDICT SUSPENSION HOOK

for Nomaddict 1 the unit	Hook reference
	VLHOOK

Frame < 5m : 2 hooks
Frame ≥ 5m : 3 hooks

for Nomaddict 2 the unit	Hook reference
	VXHOOK

3 hooks are required

HINGE REPAIR KIT

Repair kit	Reference
for Nomaddict 1	VLREPAIRKIT
for Nomaddict 2	VXREPAIRKIT

NOMADDICT 1



AND NOMADDICT 2



Model Nomaddict	Image (cm) Ht x Base	Matt white white borders	Matt white black borders	DUO : Translucent black borders + Matt white white borders	+ Matt white black borders	Flight-case (cm)
16:10 format						
Nomaddict 1	150 x 240	VL1B3150240	VL1B3150240N	VL1D1150240	VL1D1150240N	123 x 38 x 34
Nomaddict 1	183 x 293	VL1B3183293	VL1B3183293N	VL1D1183293	VL1D1183293N	123 x 38 x 34
Nomaddict 1	229 x 366	VL1B3229366	VL1B3229366N	VL1D1229366	VL1D1229366N	123 x 38 x 34
Nomaddict 1	244 x 390	VL1B3244390	VL1B3244390N	VL1D1244390	VL1D1244390N	123 x 38 x 34
Nomaddict 1	290 x 464	VL1B3290464	VL1B3290464N	VL1D1290464	VL1D1290464N	134 x 38 x 37
4:3 format						
Nomaddict 1	183 x 244	VL1B3183244	VL1B3183244N	VL1D1183244	VL1D1183244N	123 x 38 x 34
Nomaddict 1	229 x 305	VL1B3229305	VL1B3229305N	VL1D1229305	VL1D1229305N	123 x 38 x 34
Nomaddict 1	274 x 366	VL1B3274366	VL1B3274366N	VL1D1274366	VL1D1274366N	123 x 38 x 34
Nomaddict 1	320 x 427	VL1B3320427	VL1B3320427N	VL1D1320427	VL1D1320427N	123 x 38 x 34
Nomaddict 1	366 x 488	VL1B3366488	VL1B3366488N	VL1D1366488	VL1D1366488N	134 x 38 x 37
Nomaddict 2	457 x 610	VX1B3457610	VX1B3457610N	VX1D1457610	VX1D1457610N	134 x 38 x 37
Nomaddict 2	549 x 732	VX1B3549732	VX1B3549732N	VX1D1549732	VX1D1549732N	134 x 38 x 37
16:9 format						
Nomaddict 1	123 x 218	VL1B3123218	VL1B3123218N	VL1D1123218	VL1D1123218N	123 x 38 x 34
Nomaddict 1	150 x 266	VL1B3150266	VL1B3150266N	VL1D1150266	VL1D1150266N	123 x 38 x 34
Nomaddict 1	183 x 325	VL1B3183325	VL1B3183325N	VL1D1183325	VL1D1183325N	123 x 38 x 34
Nomaddict 1	206 x 366	VL1B3206366	VL1B3206366N	VL1D1206366	VL1D1206366N	123 x 38 x 34
Nomaddict 1	229 x 405	VL1B3229405	VL1B3229405N	VL1D1229405	VL1D1229405N	123 x 38 x 34
Nomaddict 1	274 x 488	VL1B3274488	VL1B3274488N	VL1D1274488	VL1D1274488N	123 x 38 x 34
Nomaddict 2	343 x 610	VX1B3343610	VX1B3343610N	VX1D1343610	VX1D1343610N	134 x 38 x 37
Nomaddict 2	411 x 732	VX1B3411732	VX1B3411732N	VX1D1411732	VX1D1411732N	134 x 38 x 37



Foot of a Nomaddict 2

NOMADDICT 1

Its clipped hinges make it very easy to assemble. Projection surface is tensioned with snap buttons.

NOMADDICT 2

For more rigidity, the frame section is 2 times larger than the one of Nomaddict 1. It is composed of 2 foldable and nestable parts delivered in 2 flight-cases.



- TRANSPORTABLE
- LARGE DIMENSIONS



FABRICS for NOMADDICT 1 and 2

FABRIC ONLY

Matt white fabric:
White borders or black borders

Translucent fabric:
Black borders



- The projection surface is attached to the frame with snap fasteners.
- Simple installation and adaptable to all configurations.



White borders



Black borders



Projection surface in its cover

Model Nomaddict	Image format Ht x Base (cm)	Matt white white borders	Matt white black borders	Translucent HG black borders
16:10 format FABRIC ONLY				
Nomaddict 1	150x240	VL2B3150240	VL2B3150240N	VL2T1150240
Nomaddict 1	183x293	VL2B3183293	VL2B3183293N	VL2T1183293
Nomaddict 1	229x366	VL2B3229366	VL2B3229366N	VL2T1229366
Nomaddict 1	244x390	VL2B3244390	VL2B3244390N	VL2T1244390
Nomaddict 1	290x464	VL2B3290464	VL2B3290464N	VL2T1290464
4:3 format FABRIC ONLY				
Nomaddict 1	183x244	VL2B3183244	VL2B3183244N	VL2T1183244
Nomaddict 1	229x305	VL2B3229305	VL2B3229305N	VL2T1229305
Nomaddict 1	274x366	VL2B3274366	VL2B3274366N	VL2T1274366
Nomaddict 1	320x427	VL2B3320427	VL2B3320427N	VL2T1320427
Nomaddict 1	366x488	VL2B3366488	VL2B3366488N	VL2T1366488
Nomaddict 2	457x610	VX2B3457610	VX2B3457610N	VX2T1457610
Nomaddict 2	549x732	VX2B3549732	VX2B3549732N	VX2T1549732
16:9 format FABRIC ONLY				
Nomaddict 1	123x218	VL2B3123218	VL2B3123218N	VL2T1123218
Nomaddict 1	150x266	VL2B3150266	VL2B3150266N	VL2T1150266
Nomaddict 1	183x325	VL2B3183325	VL2B3183325N	VL2T1183325
Nomaddict 1	206x366	VL2B3206366	VL2B3206366N	VL2T1206366
Nomaddict 1	229x405	VL2B3229405	VL2B3229405N	VL2T1229405
Nomaddict 1	274x488	VL2B3274488	VL2B3274488N	VL2T1274488
Nomaddict 2	343x610	VX2B3343610	VX2B3343610N	VX2T1343610
Nomaddict 2	411x732	VX2B3411732	VX2B3411732N	VX2T1411732



- FINISH
- REMOVABLE
- LIGHTWEIGHT

CIN'AIR

The **CIN'AIR** is an inflatable, waterproof and environmentally friendly screen. It is ideal for events and all ephemeral installations.

- Made of 1100dtex nautical PVC fabric.
- High quality structure for durable use.
- Quick and easy to set up.
- Easy to store and transport.
- 100% airtight structure, without permanent wind tunnel for a total absence of noise.

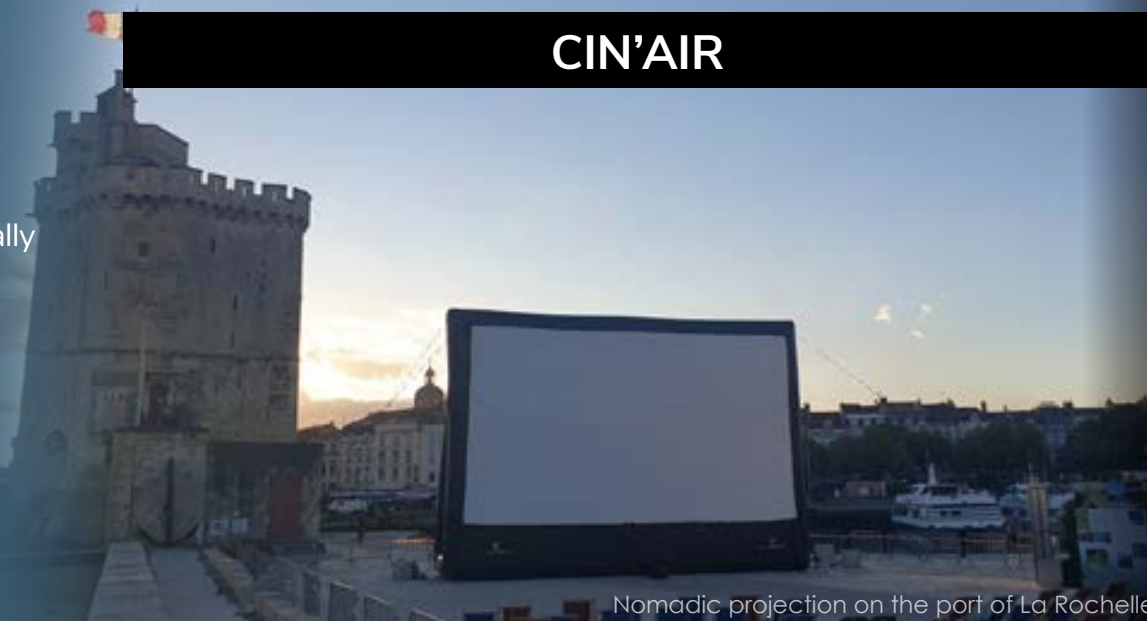

Nomadic projection on the port of La Rochelle



4 screen sizes



CIN'AIR



Image Ht x Base cm	Matt white Ref.	Bottom Black part	Total dimensions cm
280 x 490	CAB1280490	90	410 x 570
390 x 700	CAB1390700	150	600 x 810
620 x 1100	CAB16201100	150	830 x 1200
790 x 1400	CAB17901400	220	1100 x 1500

INSTALLATION

The inflation/deflation time is very fast, about 10 to 25 minutes depending on the inflator.

OPTIONS

- additional or more powerful inflator,
- different projection surfaces available according to your needs.

STORAGE

Once deflated, the structure fits in a very small space: only 2m³ for the largest size!

Other projection surfaces, please contact us.



- NOMAD
- LARGE DIMENSIONS

BUTTERFLY MOBILE

Ever more compact, the **BUTTERFLY MOBILE** is the fastest opening screen on the market. Ideal for rental or private use, up to 2m40 base.

- On both ends of the case of the screen, there is a handle and two large wheels that make it easy to carry around.
- The case design, fully made in aluminum, offers an efficient protection of the screen while carrying it around.
- Lift the top bar to open it instantly, thanks to the pantograph mechanism.



Wheels at the ends



Carrying handle



Pantograph mechanism

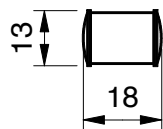

Large casing for 236cm base models

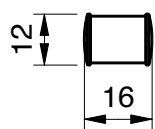

Small casing

BUTTERFLY MOBILE



Image format Ht x Base (cm)	Matt white blackout	Casing length (cm)
4:3 format	2 cm black borders	
117 x 156	BUT02B1120160	180
132 x 176	BUT02B1135180	200
147 x 196	BUT02B1150200	222
177 x 236	BUT02B1180240	262
16:9 format	2 cm black borders + drop	
110 x 196	BUT02B1112200	222
133 x 236	BUT02B1135240	262
1:1 format	2 cm black borders	
196 x 196	BUT02B1200200	222



- QUICK RELEASE
- WHEELS AT THE ENDS

FLY

FLY is a generation of simple mobile screens, compacts and robusts.

Available in 2 versions:

- Fly Mono:
Single front projection
- Green Fly:
Green background for inlay



Fly Mono



Green Fly



Telescopic upright

- The height is adjustable thanks to a telescopic upright and a tilting device ensures parallax compensation.
- A tensioning device has been specially designed to hold the screen surface taut and wrinkle free.
- The opaque projection surface bears black borders.
- Matt white screen gain: 1.1

FLY MONO

Single side front projection, black aluminum case.

Image format Ht x Base (cm)	Matt white blackout 	Casing length (cm)
16:10 format	2 cm black borders	
97,5 x 156	FLY01B1100160	170
110 x 176	FLY01B1112180	190
122,5 x 196	FLY01B1125200	210

GREEN FLY

Green background for inlay, black aluminum case.

Image format Ht x Base (cm)	Green Fly 	Casing length (cm)
Special format		
220 x 180	FLY01VV220180	190
220 x 200	FLY01VV220200	210



- DESIGN
- MULTI-FORMAT
- LIGHTWEIGHT

DRAGONFLY CROSS SCREEN MINISCREEN

The **DRAGONFLY** at the tip of innovation represents the entire know-how of ORAY in terms of mobile screens.



The **MINISCREEN** is a portable screen, ultra-light, very easy to use specially developed for Picoprojectors, to be placed on a table.

The **CROSS SCREEN** is an ultraportable screen that gets easily and quickly assembled and disassembled while offering a wide projection surface.

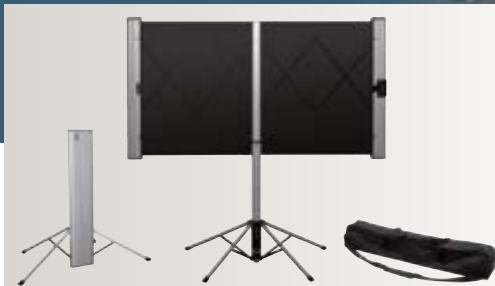

DRAGONFLY: Horizontal pantograph system



CROSS SCREEN: lightweight



MINISCREEN Open feet

DRAGONFLY



Multi-formats screen thanks to its pantograph system and horizontal opening.

- Easily carried around with its reinforced transport bag.
- Its 4-feet stand makes it very stable.
- The innovative horizontal opening offers a large screen that can fold back lengthwise, which reduces its bulkiness.

CROSS SCREEN



With its transport bag, the CrossScreen is particularly adapted to nomadic presentations. Installed in a few minutes:

- Easy and very quick to set up
- Adjustable in height
- Can be fixed to the wall

MINISCREEN



Ultra lightweight portable screen, very simple to set. It is dedicated to pico projectors and can be placed on a table.

- The black anodized aluminum housing combines lightness and quality.
- The fabric is tensioned thanks to an upright placed at the back of the casing.
- Easy to open in few seconds for your presentations to a wide audience in any circumstance.

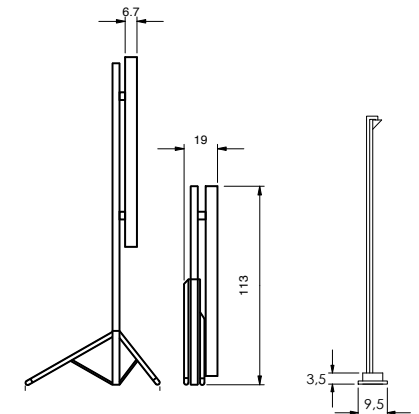

Dragonfly

Miniscreen

Image format Ht x Base (cm)	Black out Matt white Reference
3 Formats in 1: 4:3, 16:10 and 16:9	
101 x 134/ 162 /180	DRA01B1101180

Image format Ht x Base (cm)	Black out Matt white Reference
16:9 format	
75 x 133	CS1B1075133
87 x 155	CS1B1087155
100 x 177	CS1B1100177
112 x 200	CS1B1112200

Image format Ht x Base (cm)	Black out Matt white Reference
4:3 format	
79 x 102	MIN01B1079102



- TRANSPORT BAG
- COMPACT
- LIGHTWEIGHT

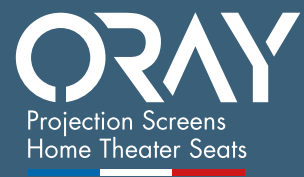

ORAY
Chemin de Beaurepaire
91410 DOURDAN - FRANCE
Tel +33 (0)1 64 59 94 54
www.oray.fr

